

DATA SHEET

SKY85608-11: 5 GHz, 802.11ac Switch / Low-Noise Amplifier Front End

Applications

- Wi-Fi-enabled handsets, tablets, and mobile systems
- System-in-Package (SiP) modules for embedded systems
- 802.11n/ac smartphones and tablets

Features

- Integrates an SP2T switch and LNA with bypass mode
- Receive gain: 12 dB
- Noise figure: 2.0 dB
- Transmit path loss: 0.6 dB
- Small DFN (8-pin, 1.5 x 1.5 mm) package (MSL1, 260 °C per JEDEC-J-STD-020)



Skyworks Green™ products are compliant with all applicable legislation and are halogen-free. For additional information, refer to Skyworks Definition of Green™, document number SQ04-0074.

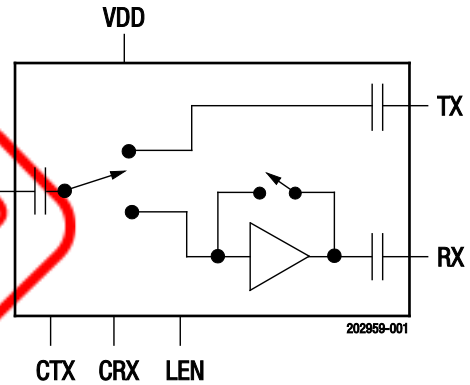
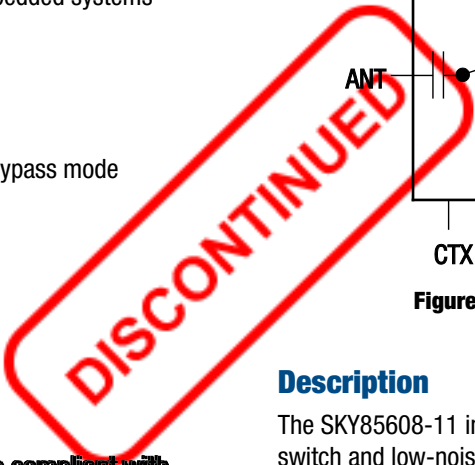

Figure 1. SKY85608-11 Block Diagram

Description

The SKY85608-11 integrates a single-pole, double-throw (SPDT) switch and low-noise amplifier (LNA) with a bypass mode in an ultra-compact package. The device is capable of switching between WLAN receive and WLAN transmit.

The SKY85608-11 is provided in a small, 8-pin, 1.5 x 1.5 mm Dual Flat No-Lead (DFN) package. A functional block diagram is shown in Figure 1. The pin configuration and package are shown in Figure 2. Signal pin assignments and functional pin descriptions are provided in Table 1.

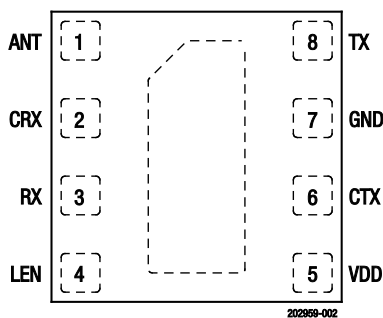

Figure 2. SKY85608-11 Pinout (Top View)

Table 1. SKY85608-11 Signal Descriptions

Pin	Name	Description	Pin	Name	Description
1	ANT	Antenna port	5	VDD	Supply voltage
2	CRX	Control signal	6	CTX	Control signal
3	RX	LNA output	7	GND	Ground
4	LEN	Control signal	8	TX	Transmit input

Electrical and Mechanical Specifications

The absolute maximum ratings of the SKY85608-11 are provided in Table 2. The recommended operating conditions are specified in Table 3, and electrical specifications are provided in Tables 4, 5, and 6.

The state of the SKY85608-11 is determined by the logic provided in Table 7.

Table 2. SKY85608-11 Absolute Maximum Ratings¹

Parameter	Symbol	Minimum	Maximum	Units
Supply voltage	V _{BAT} , V _{CC}	-0.3	+5.5	V
DC input on control pins	V _{IN}	-0.3	+3.6	V
LNA input power (RXOUT terminated in 50 Ω match)	P _{IN}		+5	dBm
Operating temperature	T _A	-40	+85	°C
Storage temperature	T _{STG}	-40	+140	°C

¹ Exposure to maximum rating conditions for extended periods may reduce device reliability. There is no damage to device with only one parameter set at the limit and all other parameters set at or below their nominal value. Exceeding any of the limits listed here may result in permanent damage to the device.

ESD HANDLING: *Although this device is designed to be as robust as possible, electrostatic discharge (ESD) can damage this device. This device must be protected at all times from ESD when handling or transporting. Static charges may easily produce potentials of several kilovolts on the human body or equipment, which can discharge without detection. Industry-standard ESD handling precautions should be used at all times.*

Table 3. Recommended Operating Conditions

Parameter	Symbol	Min	Typ	Max	Units
Supply voltage relative to ground (= 0 V)	V _{DD}	3.0	3.6	5.0	V
Control voltage:					
High	V _{IH}	1.6		3.6	V
Low	V _{IL}	0		0.4	V
Control current:					
High	I _{IH}			5	μA
Low	I _{IL}			1	μA
Operating temperature	T _A	-40	+25	+85	°C

Table 4. SKY85608-11 Electrical Specifications: DC Characteristics¹
(V_{DD} = 3.6 V, T_A = +25 °C, All Unused Ports Terminated with 50 Ω, Unless Otherwise Noted)

Parameter	Symbol	Test Condition	Min	Typ	Max	Units
Supply current	I _{CC}	LNA enabled		10.5	15	mA
		Transmit mode		30	40	μA
		Bypass mode		30	40	μA
		All off		9	15	μA

¹ Performance is guaranteed only under the conditions listed in this table.

Table 5. SKY85608-11 Electrical Specifications: Transmit (TXIN to ANT) Characteristics¹
(V_{DD} = 3.6 V, T_A = +25 °C, All Unused Ports Terminated with 50 Ω, Unless Otherwise Noted)

Parameter	Symbol	Test Condition	Min	Typ	Max	Units
Frequency	f		4900		5925	MHz
Insertion loss	TXIL	Insertion loss from TXIN input to ANT port		0.6	1	dB
1 dB input compression point (TXIN port)	IP1dB		+29	+31		dBm
Transmit input return loss (TXIN port)	S11			-14	-8	dB
Output return loss (ANT port)	S22			-14	-8	dB
TX to RXOUT isolation, bypass (loopback) mode			27	33		dB

¹ Performance is guaranteed only under the conditions listed in this table.

Table 6. SKY85608-11 Electrical Specifications: Receive (ANT to RXOUT Port) Characteristics¹
(V_{DD} = 3.6 V, T_A = +25 °C, All Unused Ports Terminated with 50 Ω, Unless Otherwise Noted)

Parameter	Symbol	Test Condition	Min	Typ	Max	Units
Frequency	f		4900		5925	MHz
Small signal gain	S21	LNA enabled	10	12	14	dB
		Bypass mode		-7		dB
LNA gain step	Gain_STEP	Gain step change between LNA normal and LNA bypass modes	18	19.5	21	dB
Gain flatness		Over 80 MHz			±0.5	dB
		Full band			±1.0	dB
Noise figure	NF	LNA enabled Bypass mode		2	2.4	dB
Third order input intercept point	IIP3	LNA enabled	+1	+4		dBm
		Bypass mode	+17	+20		dBm
Second order input intercept point	IIP2	@ 2.6 GHz		+45		dBm
Receive input return loss	S11			-9	-6	dB
Receive output return loss	S22			-14	-6	dB
Receive to transmit switching time	t _{rx-TX}	10% to 90%			300	ns
Transmit to receive switching time	t _{tx-RX}	10% to 90%			500	ns
Receive gain switching time	t _{rx}	10% to 90%			400	ns

¹ Performance is guaranteed only under the conditions listed in this table.

Table 7. SKY85608-11 Control Logic¹

Mode	CRX (Pin 2)	LEN (Pin 4)	CTX (Pin 6)
All off	0	0	0
WLAN receive	1	1	0
WLAN receive bypass	1	0	0
WLAN transmit	0	0	1

Evaluation Board Description

The SKY85608-11 Evaluation Board is used to test the performance of the SKY85608-11 LNA FEM. An Evaluation Board schematic diagram is provided in Figure 3. A photograph of the Evaluation Board is shown in Figure 4.

Evaluation Board Setup Procedure

1. Connect the system ground to pin 2 of connector J4.
2. Apply 3.3 V to VDD pin 6 or 12 of connector J4.
3. Refer to the Control Logic Table in Table 7 to set the device in the desired mode of operation. Set CRX, CTX, and LEN to appropriate VIL and VIH voltages, as specified in Table 3.
4. Transmit performance is monitored by applying an RF signal to the connector J1 (TX) and measuring the output power at the antenna port connector J2 (ANT).
5. Monitor performance in either high gain or bypass mode by applying an RF signal to the antenna port connector J2 (ANT) and measuring the output power at the receive port connector J3 (RX).

Evaluation Board Losses

The total track losses from the RF connectors of the Evaluation Board to the pins of the SKY85608 device are:

ANT: 0.25 dB

TX: 0.25 dB

RX: 0.25 dB

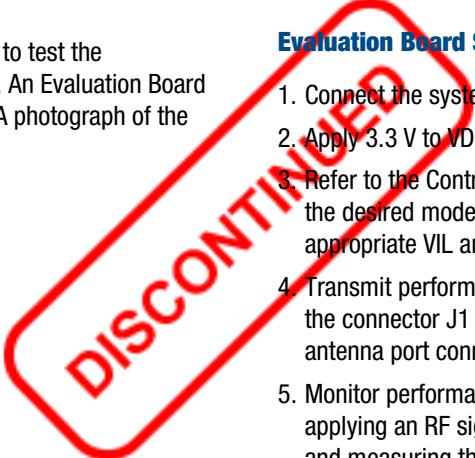

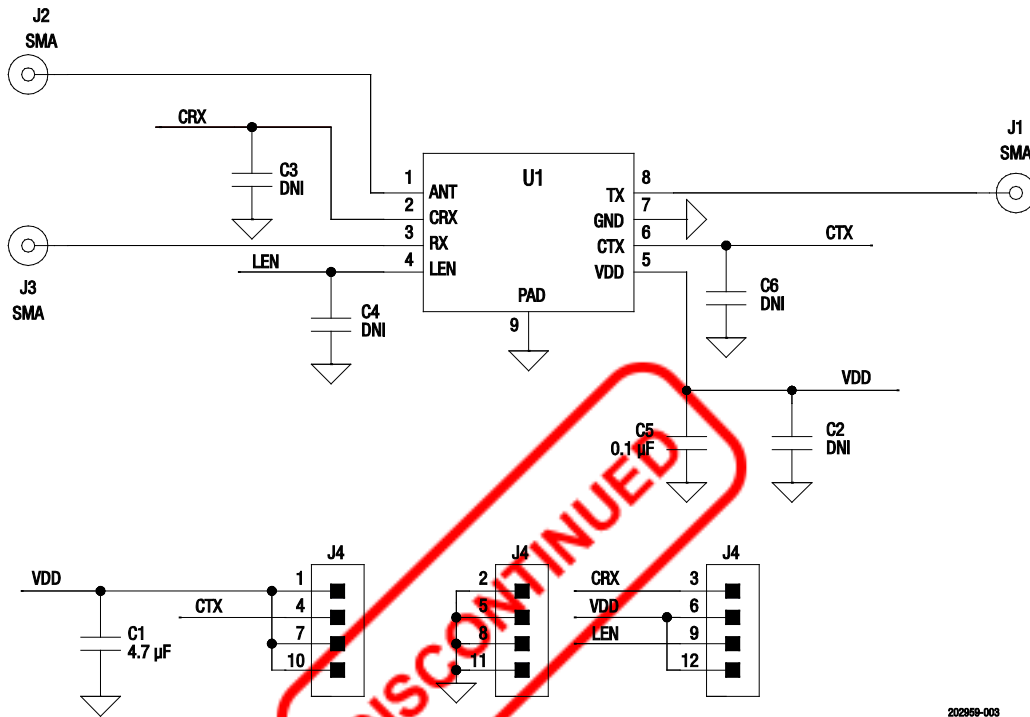

Figure 3. SKY85608-11 Evaluation Board Schematic

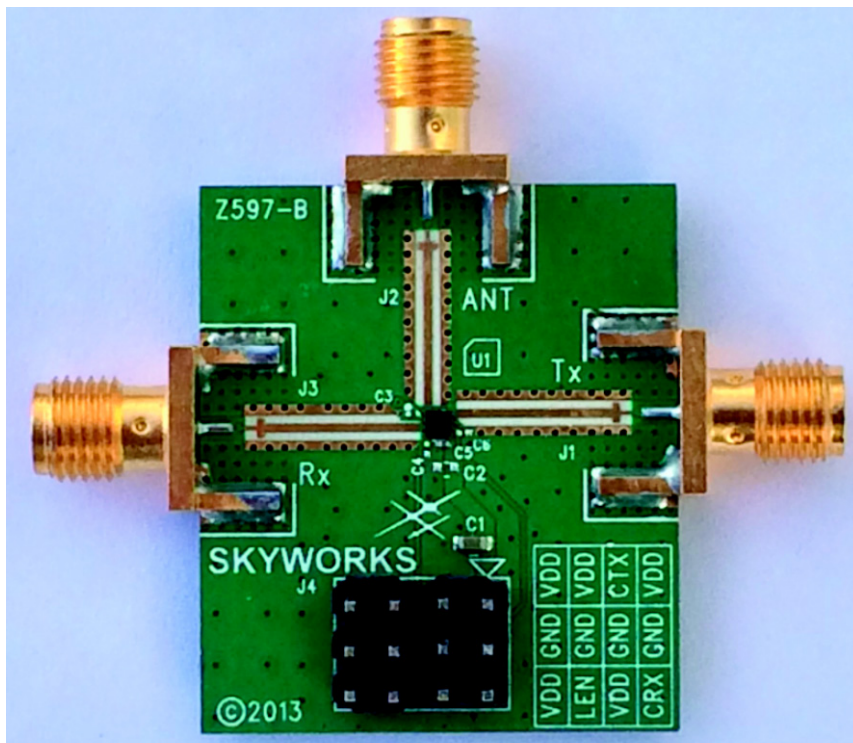

Figure 4. SKY85608-11 Evaluation Board

Package Dimensions

The PCB layout footprint for the SKY85608-11 is provided in Figure 5. A typical part marking drawing and sample photograph are shown in Figure 6. Package dimensions are shown in Figure 7, and tape and reel dimensions are provided in Figure 8.

Package and Handling Information

Instructions on the shipping container label regarding exposure to moisture after the container seal is broken must be followed. Otherwise, problems related to moisture absorption may occur when the part is subjected to high temperature during solder assembly.

The SKY85608-11 is rated to Moisture Sensitivity Level 1 (MSL1) at 260 °C. It can be used for lead or lead-free soldering. For additional information, refer to the Skyworks Application Note, *Solder Reflow Information*, document number 200164.

Care must be taken when attaching this product, whether it is done manually or in a production solder reflow environment. Production quantities of this product are shipped in a standard tape and reel format.



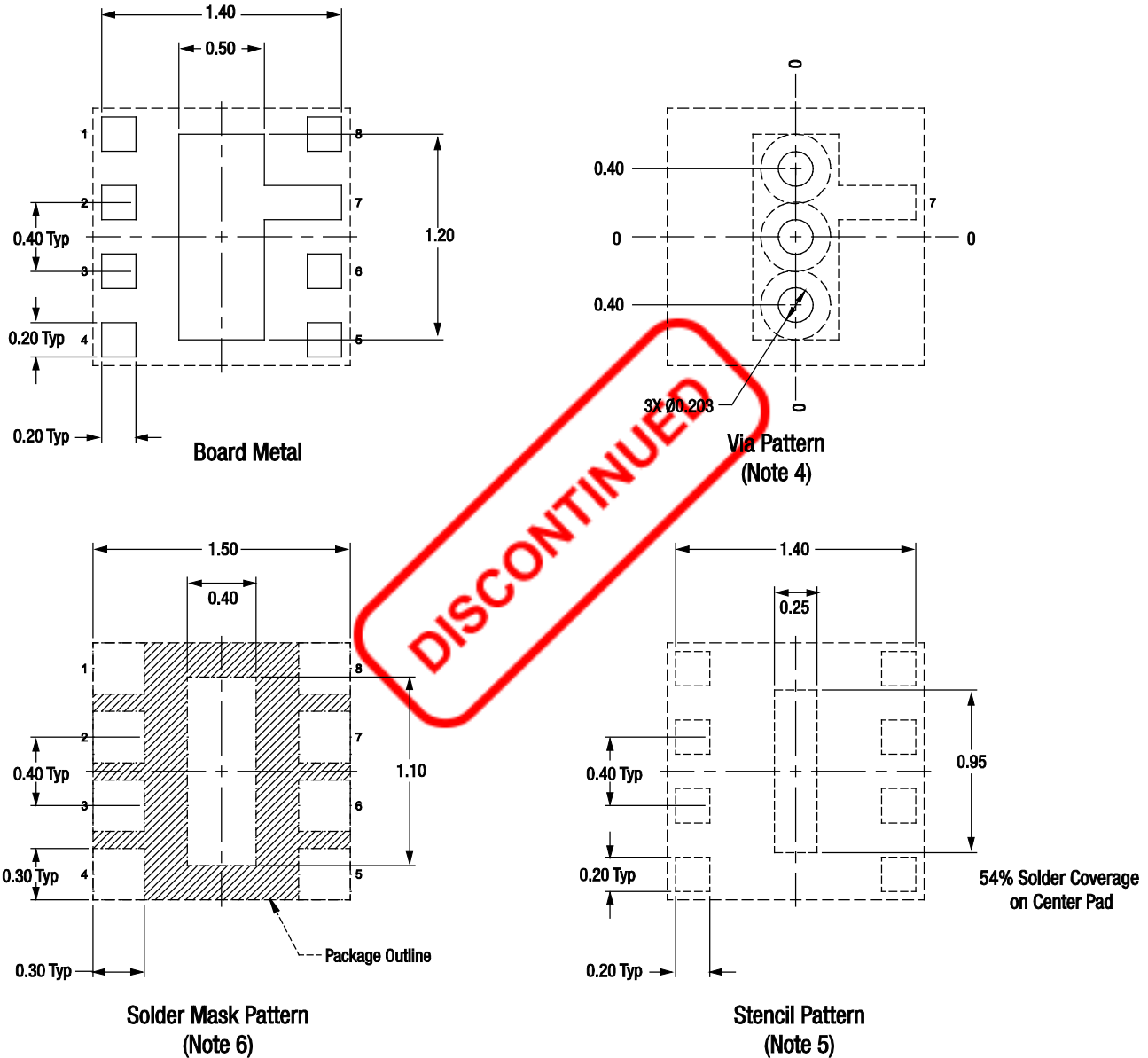

DISCONTINUED

Notes:

1. All dimensions are in millimeters
2. Dimensions and tolerances according to ASME Y14.5M-1994
3. Unless specified, dimensions are symmetrical about center lines.
4. Via hole recommendations: 0.025 mm Cu via wall plating (minimum), via holes to be filled with conductive paste and plated over.
5. Stencil recommendations: 0.10 mm stencil thickness, laser cut apertures, trapezoidal walls and rounded corners offer better paste release.
6. Solder mask recommendations: contact board fabricator for recommended solder mask offset and tolerance.

202959-005

Figure 5. SKY85608-11 PCB Layout Footprint

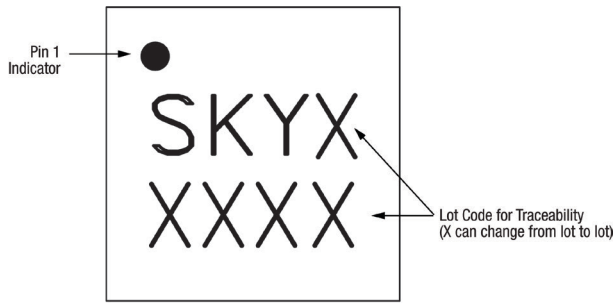

Example of Part Marking

Figure 6. Typical Part Marking

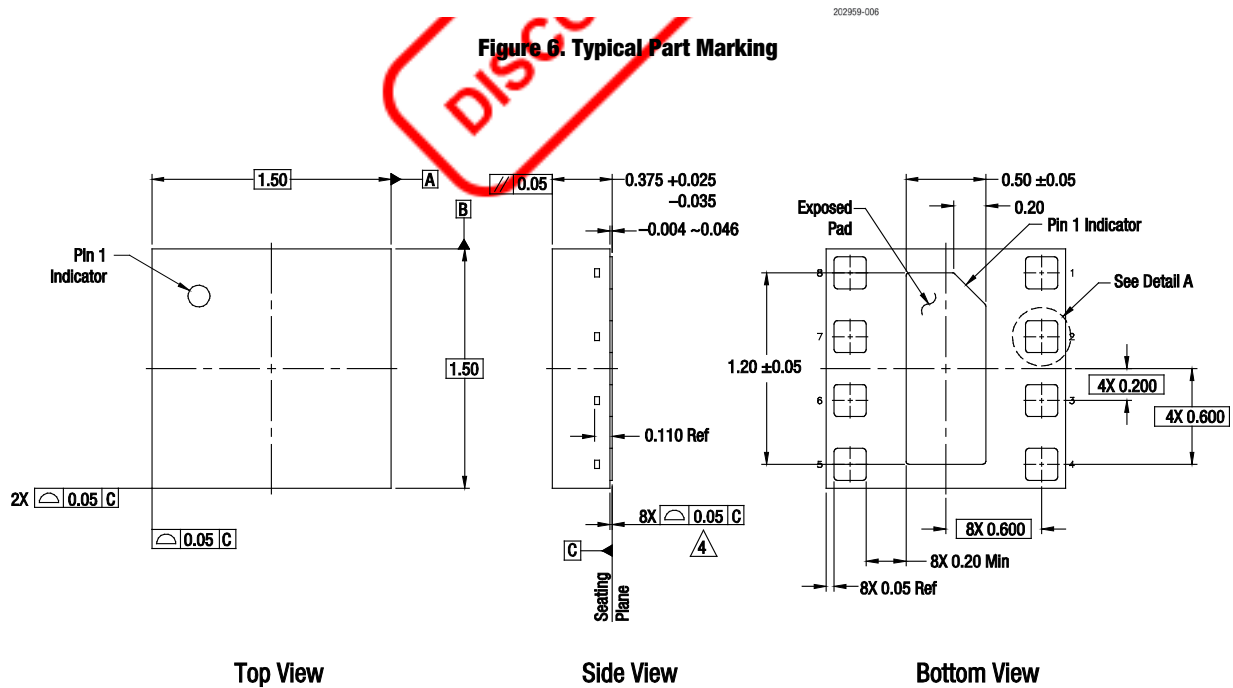

Notes:

1. Dimensions and tolerances according to ASME Y14.5M-1994.
2. All measurements are in millimeters.
3. Unless otherwise specified, the following values apply:

Decimal Tolerance:	Angular Tolerance:
X.X (1 place) ± 0.1 mm	±1/2°
X.XX (2 places) ± 0.05 mm	
X.XXX (3 places) ± 0.025 mm	

4. Coplanarity applies to the terminals as well as all other bottom surface metallization.
5. Dimension applies to metallized terminal. If terminal tip has a radius, the dimension should not be measured in that radius area.
6. Unless specified, dimensions are symmetrical about center lines.

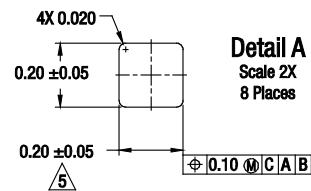

Figure 7. SKY85608-11 Package Dimensions

202959-007

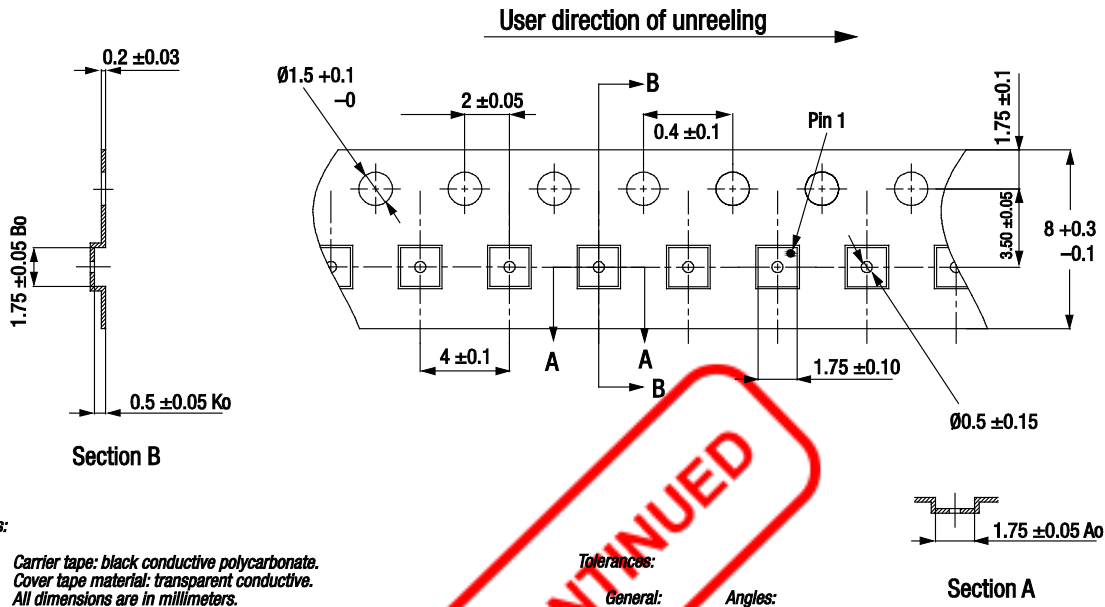

Figure 8. SKY85608-11 Tape and Reel Dimensions

202959-008

Ordering Information

Part Number	Product Description	Evaluation Board Part Number
SKY85608-11	5 GHz, 802.11ac Switch / LNA Front End	SKY85608-11EK1



Copyright © 2013-2018, 2020, 2024, Skyworks Solutions, Inc. All Rights Reserved.

Information in this document is provided in connection with Skyworks Solutions, Inc. ("Skyworks") products or services. These materials, including the information contained herein, are provided by Skyworks as a service to its customers and may be used for informational purposes only by the customer. Skyworks assumes no responsibility for errors or omissions in these materials or the information contained herein. Skyworks may change its documentation, products, services, specifications or product descriptions at any time, without notice. Skyworks makes no commitment to update the materials or information and shall have no responsibility whatsoever for conflicts, incompatibilities, or other difficulties arising from any future changes.

No license, whether express, implied, by estoppel or otherwise, is granted to any intellectual property rights by this document. Skyworks assumes no liability for any materials, products or information provided hereunder, including the sale, distribution, reproduction or use of Skyworks products, information or materials, except as may be provided in Skyworks' Terms and Conditions of Sale.

THE MATERIALS, PRODUCTS AND INFORMATION ARE PROVIDED "AS IS" WITHOUT WARRANTY OF ANY KIND, WHETHER EXPRESS, IMPLIED, STATUTORY, OR OTHERWISE, INCLUDING FITNESS FOR A PARTICULAR PURPOSE OR USE, MERCHANTABILITY, PERFORMANCE, QUALITY OR NON-INFRINGEMENT OF ANY INTELLECTUAL PROPERTY RIGHT; ALL SUCH WARRANTIES ARE HEREBY EXPRESSLY DISCLAIMED. SKYWORKS DOES NOT WARRANT THE ACCURACY OR COMPLETENESS OF THE INFORMATION, TEXT, GRAPHICS OR OTHER ITEMS CONTAINED WITHIN THESE MATERIALS. SKYWORKS SHALL NOT BE LIABLE FOR ANY DAMAGES, INCLUDING BUT NOT LIMITED TO ANY SPECIAL, INDIRECT, INCIDENTAL, STATUTORY, OR CONSEQUENTIAL DAMAGES, INCLUDING WITHOUT LIMITATION, LOST REVENUES OR LOST PROFITS THAT MAY RESULT FROM THE USE OF THE MATERIALS OR INFORMATION, WHETHER OR NOT THE RECIPIENT OF MATERIALS HAS BEEN ADVISED OF THE POSSIBILITY OF SUCH DAMAGE.

Skyworks products are not intended for use in medical, lifesaving or life-sustaining applications, or other equipment in which the failure of the Skyworks products could lead to personal injury, death, physical or environmental damage. Skyworks customers using or selling Skyworks products for use in such applications do so at their own risk and agree to fully indemnify Skyworks for any damages resulting from such improper use or sale.

Customers are responsible for their products and applications using Skyworks products, which may deviate from published specifications as a result of design defects, errors, or operation of products outside of published parameters or design specifications. Customers should include design and operating safeguards to minimize these and other risks. Skyworks assumes no liability for applications assistance, customer product design, or damage to any equipment resulting from the use of Skyworks products outside of Skyworks' published specifications or parameters.

Skyworks, the Skyworks symbol, Sky5®, SkyOne®, SkyBlue™, Skyworks Green™, ClockBuilder®, DSPLL®, ISOmodem®, ProSLIC®, SiPHY®, and RFelC® are trademarks or registered trademarks of Skyworks Solutions, Inc. or its subsidiaries in the United States and other countries. Third-party brands and names are for identification purposes only and are the property of their respective owners. Additional information, including relevant terms and conditions, posted at www.skyworksinc.com, are incorporated by reference.