

DATA SHEET

SKY85736-11: 5 GHz WLAN Front-End Module

Applications

- 802.11ac networking and personal computing systems
- PC cards, PCMCIA cards, mini-cards, and half mini-cards
- WLAN-enabled wireless video systems

Features

- Integrated high-performance 5 GHz PA, LNA with bypass, and T/R switch
- Fully matched input and output
- Integrated power detector and directional coupler
- Transmit gain: 32 dB
- Receive gain: > 14 dB
- Output power: +22 dBm @ -35 dB DEVM, HT80, MCS9, 5 V
- Output power: +23 dBm @ -30 dB DEVM, HT40, MCS7, 5 V
- Small laminate (24-pin, 3 x 5 mm) package (MSL3, 260 °C per JEDEC J-STD-020)



Skyworks Green™ products are compliant with all applicable legislation and are halogen-free. For additional information, refer to *Skyworks Definition of Green™*, document number SQ04-0074.

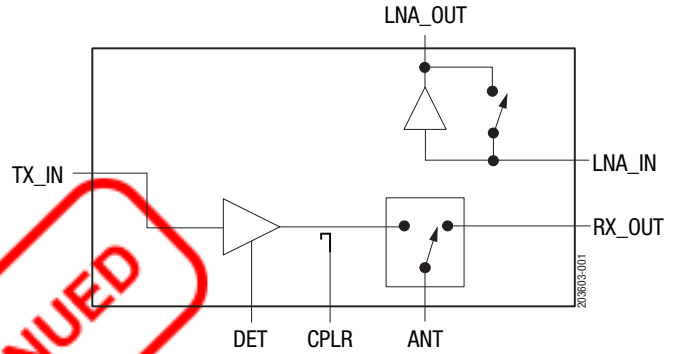

Figure 1. SKY85736-11 Block Diagram

Description

The SKY85736-11 is a highly integrated, 5 GHz front-end module (FEM) incorporating a 5 GHz single-pole, double-throw (SPDT) transmit/receive (T/R) switch, a 5 GHz high-gain low-noise amplifier (LNA) with bypass, and a 5 GHz power amplifier (PA) intended for high-power 802.11ac applications and systems.

The LNA and PA disable functions ensure low leakage current in the off mode. An integrated power detector is included to provide closed-loop power control within the system.

The device is provided in a compact, 24-pin 3 x 5 mm laminate package, which may reduce the front-end board space by more than 50 percent. A functional block diagram is shown in Figure 1. The pin configuration and package are shown in Figure 2. Signal pin assignments and functional pin descriptions are provided in Table 1.

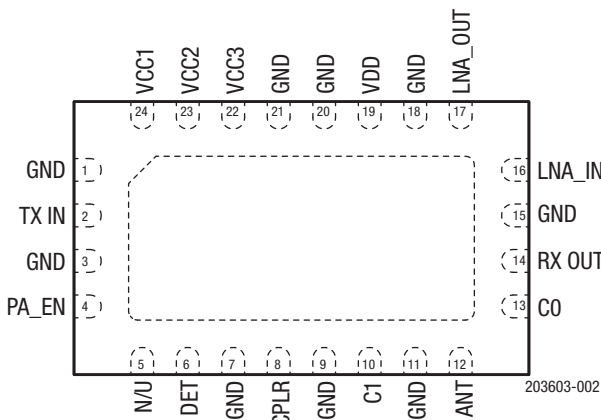
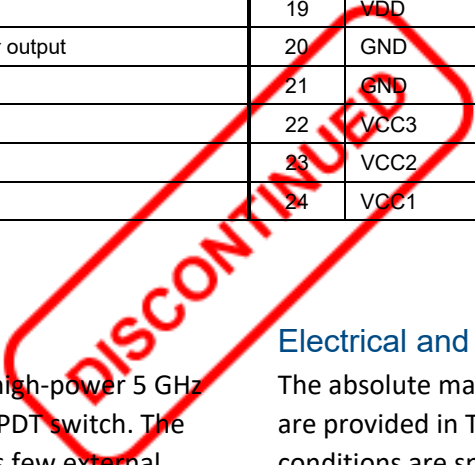

Figure 2. SKY85736-11 Pinout (Top View)

Table 1. SKY85736-11 Signal Descriptions

| Pin | Name | Description | Pin | Name | Description |
|-----|-------|-------------------------|-----|---------|--------------------------------|
| 1 | GND | Ground | 13 | C0 | Control pin 0 |
| 2 | TX_IN | Transmit input | 14 | RX_OUT | Switch RX output |
| 3 | GND | Ground | 15 | GND | Ground |
| 4 | PA_EN | PA enable | 16 | LNA_IN | LNA input |
| 5 | N/U | Not used (open circuit) | 17 | LNA_OUT | LNA output |
| 6 | DET | Detector output | 18 | GND | Ground |
| 7 | GND | Ground | 19 | VDD | LNA supply voltage |
| 8 | CPLR | DPD coupler output | 20 | GND | Ground |
| 9 | GND | Ground | 21 | GND | Ground |
| 10 | C1 | Control pin 1 | 22 | VCC3 | PA third stage supply voltage |
| 11 | GND | Ground | 23 | VCC2 | PA second stage supply voltage |
| 12 | ANT | Antenna | 24 | VCC1 | PA first stage supply voltage |



Technical Description

The SKY85736-11 is comprised of a high-power 5 GHz PA, a 5 GHz LNA, and a broadband SPDT switch. The device is fully-matched, and requires few external components for optimal performance, which makes it ideal for small portable/mobile applications. The FEM provides up to +31 dB of transmit gain over the frequency band. The LNA supports an enable/disable mode for power savings when not in receive mode and a bypass function for increased receive dynamic range. The PA can be shut off using the PA_EN signal (pin 4).

The low-loss broadband switch provides the T/R switching function on the SKY85736-11 and has a 1 dB output compression point (OP1dB) of approximately +30 dBm.

Electrical and Mechanical Specifications

The absolute maximum ratings of the SKY85736-11 are provided in Table 2. The recommended operating conditions are specified in Table 3 and electrical specifications are provided in Table 4.

The state of the SKY85736-11 is determined by the logic provided in Table 5.

Table 2. SKY85736-11 Absolute Maximum Ratings¹

| Parameter | Symbol | Minimum | Maximum | Units |
|--|---------------------------|---------|---------|-------|
| Supply voltage | VCC1, VCC2, VCC3, and VDD | -0.3 | +6.0 | V |
| DC input on control pins (C0, C1, and PA_EN) | V _{IN} | -0.3 | +3.6 | V |
| Input power (50 Ω load) | P _{IN} | | +10 | dBm |
| Supply current | I _{CC} | | 500 | mA |
| Storage temperature | T _{ST} | -40 | +150 | °C |
| Junction temperature | T _J | | 150 | °C |
| Electrostatic discharge: Human Body Model (HBM), Class 1C | ESD | | 1000 | V |

¹ Exposure to maximum rating conditions for extended periods may reduce device reliability. There is no damage to device with only one parameter set at the limit and all other parameters set at or below their nominal value. Exceeding any of the limits listed here may result in permanent damage to the device.

ESD HANDLING: Although this device is designed to be as robust as possible, electrostatic discharge (ESD) can damage this device. This device must be protected at all times from ESD when handling or transporting. Static charges may easily produce potentials of several kilovolts on the human body or equipment, which can discharge without detection. Industry-standard ESD handling precautions should be used at all times.

Table 3. SKY85736-11 Recommended Operating Conditions

| Parameter | Symbol | Min | Typ | Max | Units |
|------------------------|---------------------------|-----|-----|------|-------|
| Supply voltage | VCC1, VCC2, VCC3, and VDD | 4.5 | 5.0 | 5.25 | V |
| Control logic: High | V _{IH} | 1.6 | | 3.6 | V |
| Low | V _{IL} | 0 | | 0.4 | V |
| PA enable current | I _{ENABLE} | | 10 | 20 | μA |
| LNA bias current | I _{DD} | | 15 | 18 | mA |
| C0, C1 enable current | | | | 10 | μA |
| Operating temperature | T _{OP} | -40 | | +85 | °C |

DATA SHEET • SKY85736-11: 5 GHz WLAN FRONT-END MODULE

Table 4. SKY85736-11 Electrical Specifications¹ (1 of 2)
(VCC1 = VCC2 = VCC3 = VDD = 5.0 V, Top = 25 °C, Unless Otherwise Noted)

| Parameter | Symbol | Test Condition | Min | Typ | Max | Units |
|---|-----------------------|---|---------------------------------|---------------------------------|-------------------|---------------------------------|
| Frequency range | f | Main frequency band | 5.15 | | 5.85 | GHz |
| Transmit Mode | | | | | | |
| Gain | G G _{3.9} | At 3.9 GHz | 28 | 32 -4 | 0 | dB dB |
| Gain flatness | | Over any 40 MHz bandwidth | -0.5 | | +0.5 | dB |
| Output power | P _{OUT} | With -45 dB EVM source: 11a, 11n mask compliant, HT20 11a OFDM54, HT20; -30 dB DEVM 11n MCS7, HT40, -30 dB DEVM 11n MCS7, HT40, -34 dB DEVM 11ac MCS9, HT80, -35 dB DEVM | +25 +21 +21 +19 +20 | +27 +23 +23 +22 +22 | | dBm dBm dBm dBm dBm |
| Current consumption | | Modulated signal: @ Quiescent @ +22 dBm @ +23 dBm @ +26 dBm Leakage, EN off | | 200 320 340 440 50 | 350 370 500 | mA mA mA mA µA |
| 2 nd harmonics | 2fo | +26 dBm MCS0, UNII-2, -3 | | -50 | -40 | dBm/MHz |
| 3 rd harmonics | 3fo | +26 dBm MCS0, UNII-2, -3 | | -50 | -40 | dBm/MHz |
| All spurious | | +26 dBm OFDM, 6 Mbps | | -28 | -25 | dBm |
| Isolation | | From ANT to RX in TX mode (switch leakage + LNA S21 when off) From ANT to TX in RX mode (switch leakage + PA S12 when off) | | | -40 -40 | dB dB |
| Input return loss | S ₁₁ | | | 10 | | dB |
| Output return loss | S ₂₂ | | | 15 | | dB |
| Power detector output: @ No RF @ +10 dBm @ +26 dBm | | | | 0.15 0.48 0.88 | | V V V |
| Coupler coupling factor ² | CPLG | | | -15 | | dB |
| Coupler directivity | DIR | | | 17 | | dB |
| Power detector output impedance | Z _{OUT_DE T} | RF output = -30 dBm | | 1400 | | Ω |
| PA turn-on time | | From 10% ↔ 90% power change of rising or falling edge, state 1 | | | 500 | ns |
| Ruggedness | Ru | TX_IN = 10 dBm, 10:1 mismatch, all phases | No permanent damage | | | |

DATA SHEET • SKY85736-11: 5 GHz WLAN FRONT-END MODULE

Table 4. SKY85736-11 Electrical Specifications¹ (2 of 2)
 (VCC1 = VCC2 = VDD = 5.0 V, TOP = 25 °C, Unless Otherwise Noted)

| Parameter | Symbol | Test Condition | Min | Typ | Max | Units |
|-----------------------------------|--------|---------------------------|----------|-----------|----------|------------|
| Receive Mode | | | | | | |
| Gain | G | | 14 | 16 | | dB |
| 1 dB input compression point | IP1dB | LNA active LNA bypass | | -5 +19 | | dBm dBm |
| Gain step | | | | 22 | | dB |
| Gain flatness | | Over any 40 MHz bandwidth | -0.25 | | +0.25 | dB |
| Noise figure | NF | End to end | | 2.2 | | dB |
| Input return loss | S11 | LNA active LNA bypass | 10 10 | | | dB dB |
| Output return loss | S22 | LNA active LNA bypass | | 10 6 | | dB |
| Third order input intercept point | IIP3 | LNA active | -3 | +3 | | dBm |
| Switching time | tsw | LNA ↔ bypass RX ↔ TX | | | 300 1 | ns μs |
| Receive Bypass Mode | | | | | | |
| Insertion loss | S21 | | -11 | -6 | | dB |

¹ Performance is guaranteed only under the conditions listed in this table.

² The coupling factor applies to the coupler itself; it is not relative to the FEM output.

Table 5. SKY85736-11 Logic

| Mode | State | PEN | C0 | C1 |
|------------------|---------------|-----|----|----|
| TX to ANT | 1 | 1 | 0 | 1 |
| RX LNA to ANT | 2 | 0 | 1 | 0 |
| RX bypass to ANT | 3 | 0 | 1 | 1 |
| All off | 4 | 0 | 0 | 0 |
| All other states | Not supported | | | |

Evaluation Board Description

The SKY85736-11 Evaluation Board is used to test the performance of the SKY85736-11 FEM. A suggested application schematic diagram is shown in Figure 3. A photograph of the Evaluation Board is shown in Figure 4. Table 6 provides the Bill of Materials (BOM) list for Evaluation Board components.

Evaluation Board Setup Procedure

1. Place jumpers between J4 and J6 at pins 6, 8, 9, and 10.
2. Apply 5 V to pins 2 and 3 of the J5 header (pin 1 ground).
3. Select a path according to the information in Table 5 by applying control voltage (L = 0 V, H = 3.3 V) to PA_EN (J6 header, pin 13), C0 (J6 header, pin 9), and C1 (J6 header, pin 7).

NOTE: Do not use a jumper from these three pins to VCC_LNA. This voltage may be at 5 V to bias the LNA.

4. Detector output can be measured on the J4 header, pin 1.

Circuit Design Considerations

The following design considerations are general in nature and must be followed regardless of final use or configuration:

- Paths to ground should be made as short as possible.
- The ground pad of the SKY85736-11 has special electrical and thermal grounding requirements. This pad is the main thermal conduit for heat dissipation. Because the circuit board acts as the heat sink, it must shunt as much heat as possible from the device.
Therefore, design the connection to the ground pad to dissipate the maximum wattage produced by the circuit board. Multiple vias to the grounding layer are required.
- TX_IN is DC shorted to GND. There is no DC leaking from the chip, but if there is DC on the line interfacing with the TX_IN pin, a 10 pF blocking capacitor is recommended.
- ANT, RX_OUT, and LNA_IN are DC blocked and do not require blocking capacitors.
- LNA_OUT is DC blocked but if there is > 1.5 V DC on the line connected to the LNA_OUT pin, a 10 pF blocking capacitor is recommended.

NOTE: A poor connection between the ground pad and ground increases junction temperature (T_J), which reduces the life of the device.

DATA SHEET • SKY85736-11: 5 GHz WLAN FRONT-END MODULE

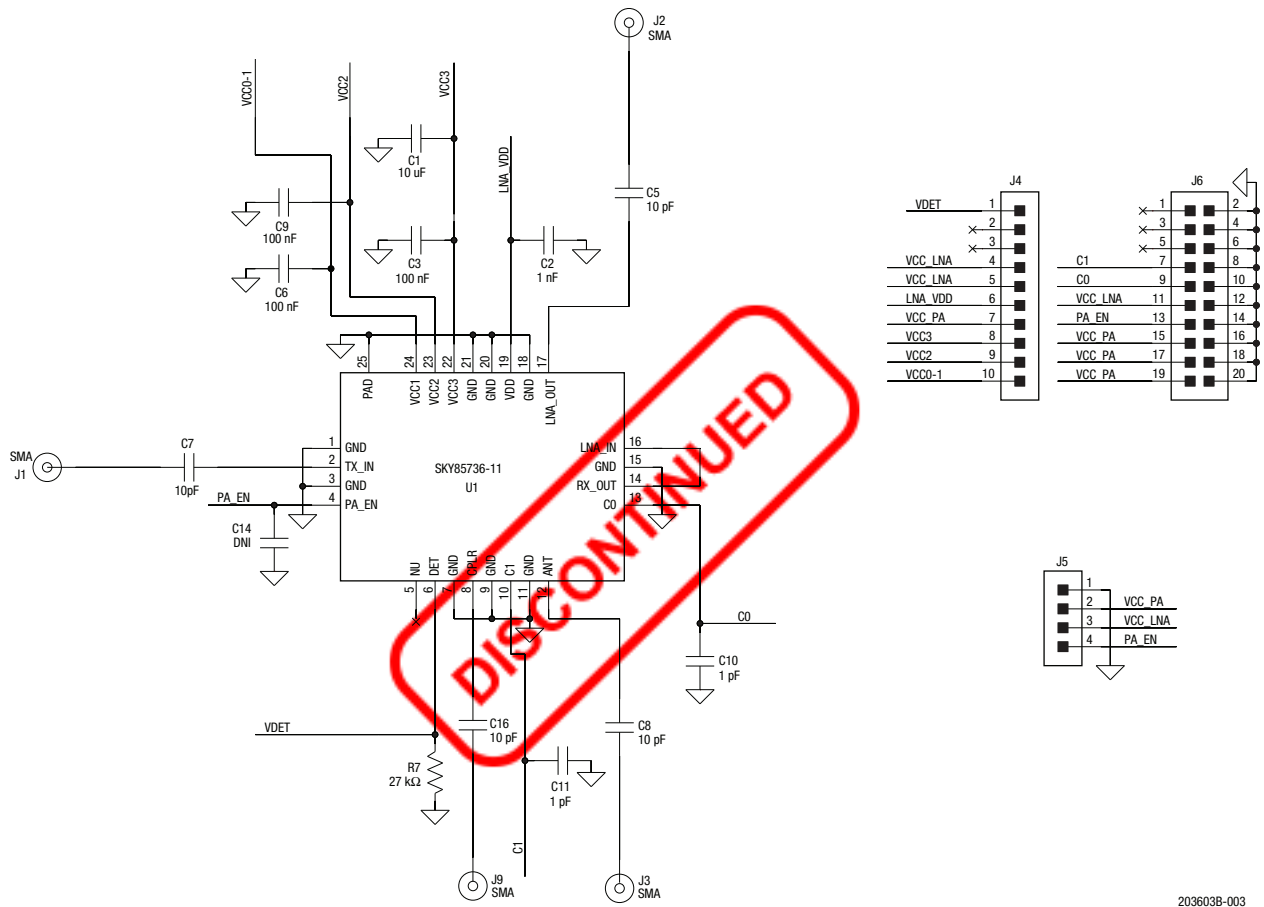

Figure 3. SKY85736-11 Application Schematic

203603B-003

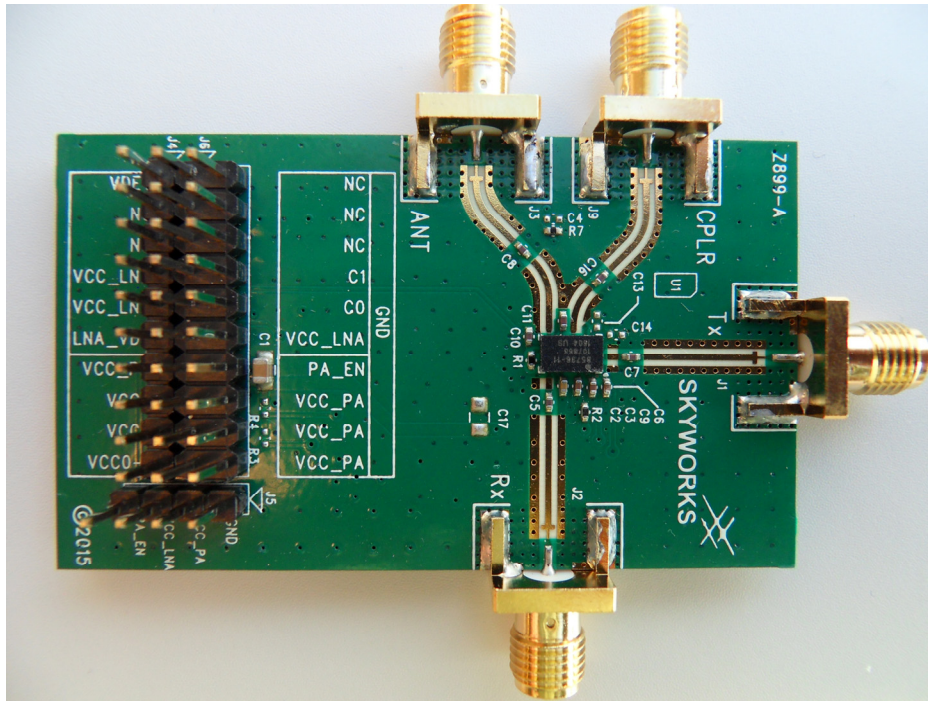

Figure 4. SKY85736-11 Evaluation Board

Table 6. SKY85736-11 Evaluation Board Bill of Materials

| Component | Value | Size | Vendor | Part Number | Description |
|------------|-------------|--------------------|--------------------|-------------|--|
| C1 | 10 uF | Murata | GRM21BR71A106KE51L | 0805 | Ceramic |
| C2 | 1 nF | Murata | GRM1555C1H102JA01 | 0402 | Multilayer ceramic |
| C3, C6, C9 | 100 nF | Murata | GRM155R71C104KA88D | 0402 | Monolithic ceramic |
| C5, C7, C8 | 10 pF | Murata | GRM1555C1H100JZ01 | 0402 | Multilayer ceramic |
| C10,C11 | 1 pF | Murata | GRM1555C1H1R0CZ01 | 0402 | Multilayer ceramic |
| C16 | 10 pF | Murata | GJM1555C1H100GB01 | 0402 | RF, high Q, low loss |
| R7 | 27 kΩ | Panasonic | ERJ2GEJ273 | 0402 | Thick film chip resistor |
| U1 | SKY85736-11 | Skyworks Solutions | SKY85736-11 | MCM3x5-24 | 802.11ac 5GHz 21dBm FEM with PA, SW, LNA |

Package Dimensions

The PCB layout footprint for the SKY85736-11 is shown in Figure 5. Typical part markings are shown in Figure 6. Package dimensions are shown in Figure 7, and tape and reel dimensions are provided in Figure 8.

Package and Handling Information

Since the device package is sensitive to moisture absorption, it is baked and vacuum packed before shipping. Instructions on the shipping container label regarding exposure to moisture after the container seal is broken must be followed. Otherwise, problems related to moisture absorption may occur when the part is subjected to high temperature during solder assembly.

The SKY85736-11 is rated to Moisture Sensitivity Level 3 (MSL3) at 260 °C. It can be used for lead or lead-free soldering. For additional information, refer to the Skyworks Application Note, *Solder Reflow Information*, document number 200164.

Care must be taken when attaching this product, whether it is done manually or in a production solder reflow environment. Production quantities of this product are shipped in a standard tape and reel format.

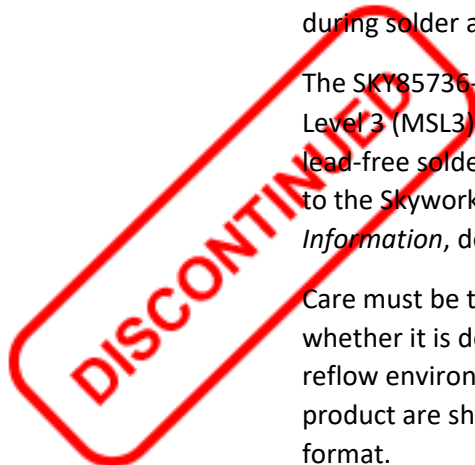

DATA SHEET • SKY85736-11: 5 GHz WLAN FRONT-END MODULE

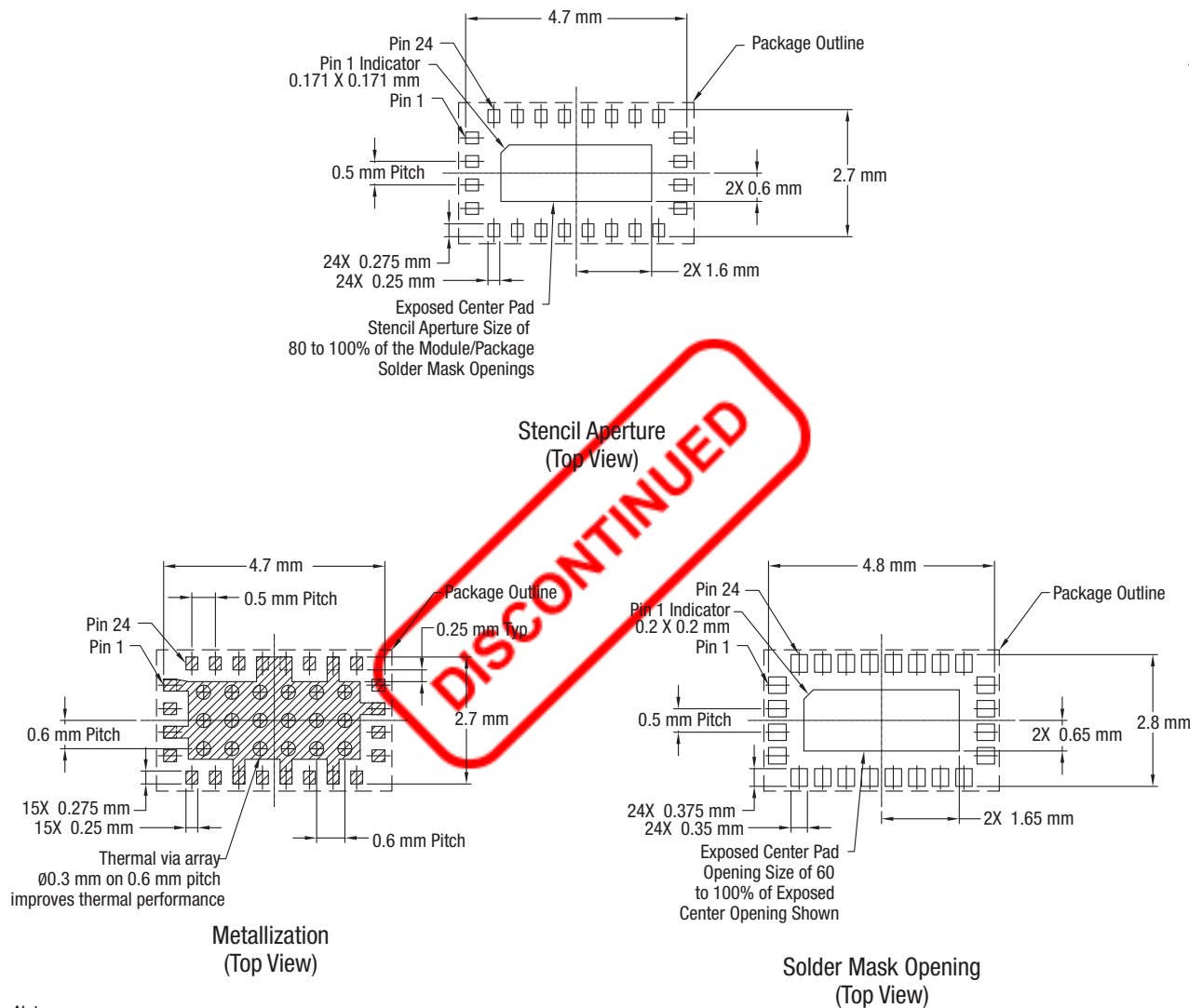

Notes:

1. All measurements are in millimeters.
2. Thermal vias should be resin filled and capped in accordance with IPC-4761 type VII vias. Recommended Cu thickness is 30 to 35 µm.

203603-005

Figure 5. SKY85736-11 PCB Layout Footprint (Top View)

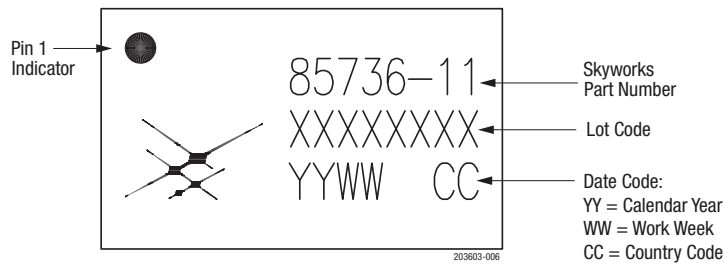

Figure 6. Typical Part Markings (Top View)

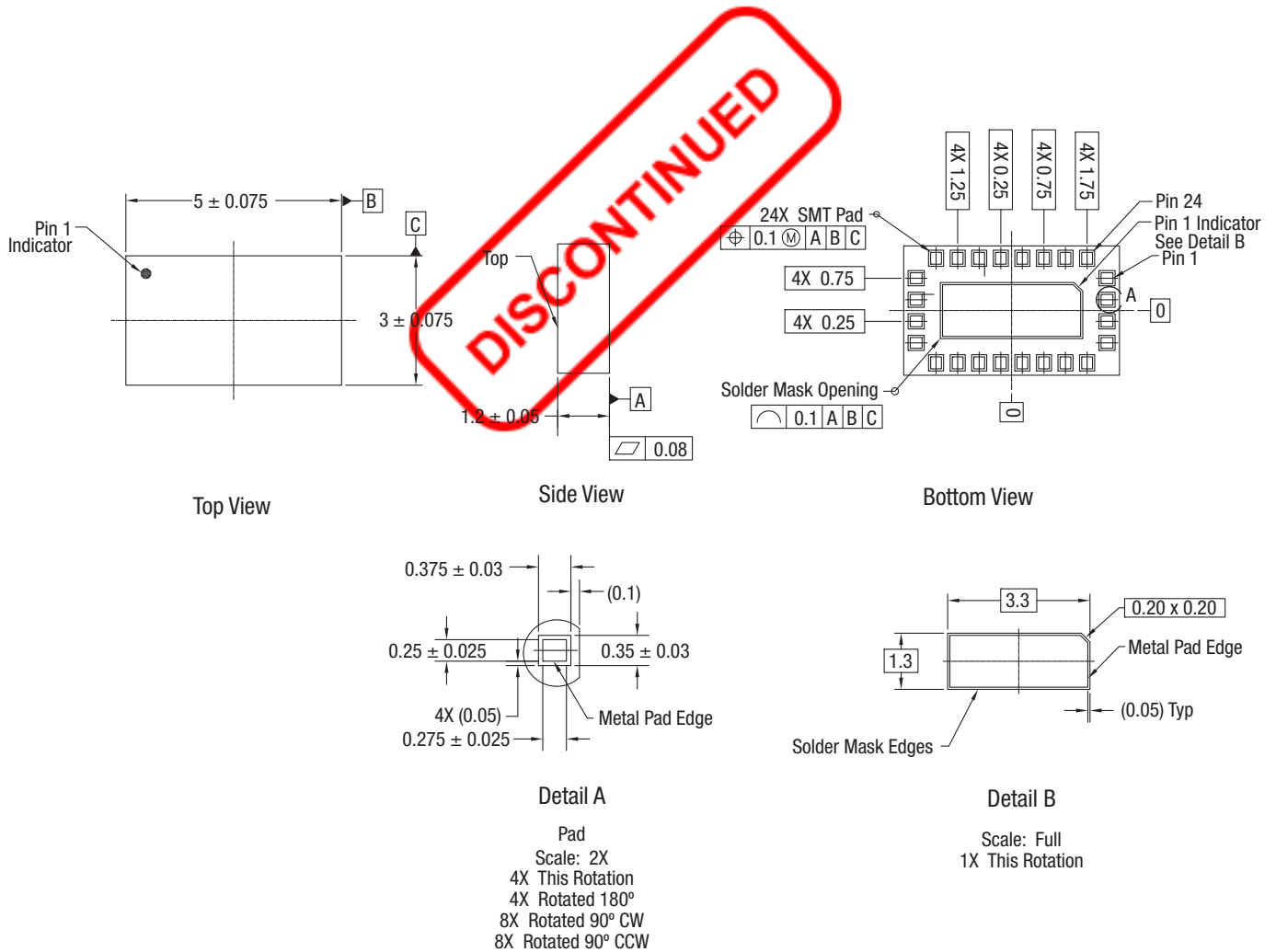

Figure 7. SKY85736-11 Package Dimensions

Notes:

1. Dimensions and tolerances in accordance with ASME Y14.5M-1994.
2. All measurements are in millimeters.
3. Primary datum A and seating plane are defined by spherical crowns of the solder balls.
4. Dimension is measured at the maximum solder ball diameter, parallel to primary datum A.

203603-007

DATA SHEET • SKY85736-11: 5 GHz WLAN FRONT-END MODULE

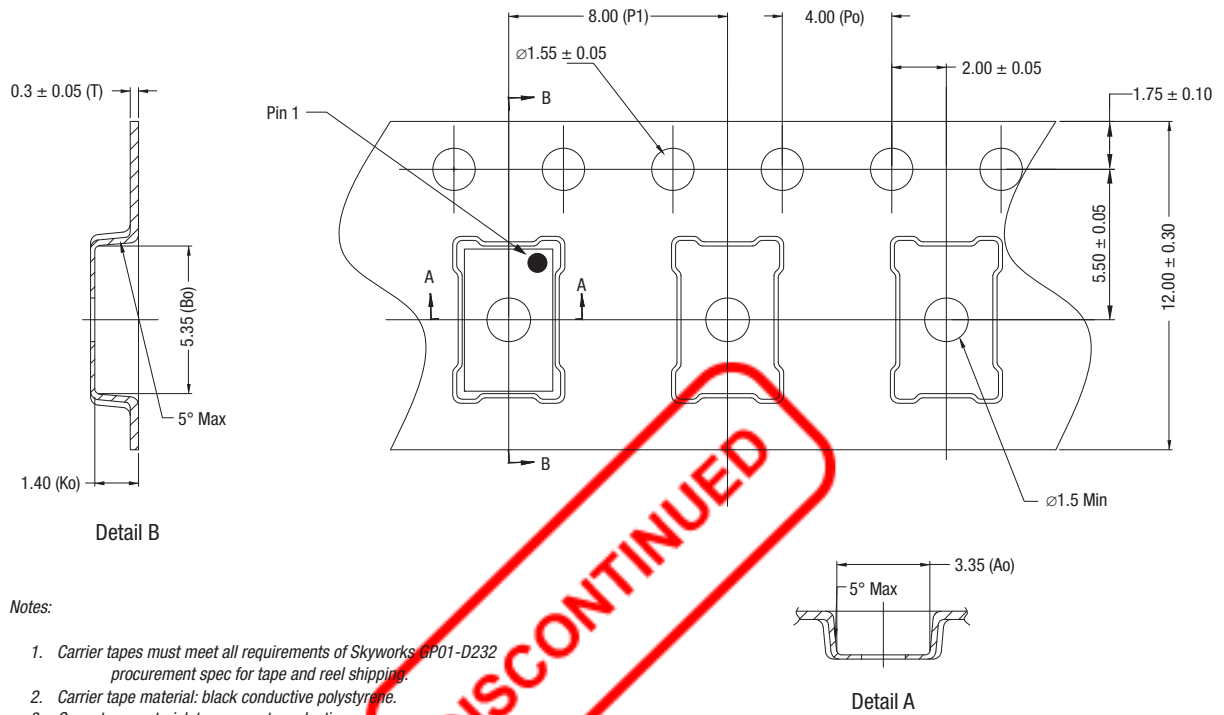

Notes:

1. Carrier tapes must meet all requirements of Skyworks 0P01-D232 procurement spec for tape and reel shipping.
2. Carrier tape material: black conductive polystyrene.
3. Cover tape material: transparent conductive.
4. ESD-surface resistivity is $\leq 1 \times 10^{10}$ Ohms/square per EIA, JEDEC TNR Specification.
5. P_0, P_1 , 10-sprocket hole pitch cumulative tolerance: ± 0.20 mm.
6. A_0 and B_0 measurement point to be 0.30 mm from bottom pocket.
7. All dimensions are in millimeters.

203603-008

Figure 8. SKY85736-11 Tape and Reel Dimensions

Ordering Information

| Part Number | Product Description | Evaluation Board Part Number |
|-------------|-----------------------------|------------------------------|
| SKY85736-11 | 5 GHz WLAN Front-End Module | SKY85736-11EK1 |



Copyright © 2015-2018, 2024 Skyworks Solutions, Inc. All Rights Reserved.

Information in this document is provided in connection with Skyworks Solutions, Inc. ("Skyworks") products or services. These materials, including the information contained herein, are provided by Skyworks as a service to its customers and may be used for informational purposes only by the customer. Skyworks assumes no responsibility for errors or omissions in these materials or the information contained herein. Skyworks may change its documentation, products, services, specifications or product descriptions at any time, without notice. Skyworks makes no commitment to update the materials or information and shall have no responsibility whatsoever for conflicts, incompatibilities, or other difficulties arising from any future changes.

No license, whether express, implied, by estoppel or otherwise, is granted to any intellectual property rights by this document. Skyworks assumes no liability for any materials, products or information provided hereunder, including the sale, distribution, reproduction or use of Skyworks products, information or materials, except as may be provided in Skyworks' Terms and Conditions of Sale.

THE MATERIALS, PRODUCTS AND INFORMATION ARE PROVIDED "AS IS" WITHOUT WARRANTY OF ANY KIND, WHETHER EXPRESS, IMPLIED, STATUTORY, OR OTHERWISE, INCLUDING FITNESS FOR A PARTICULAR PURPOSE OR USE, MERCHANTABILITY, PERFORMANCE, QUALITY OR NON-INFRINGEMENT OF ANY INTELLECTUAL PROPERTY RIGHT; ALL SUCH WARRANTIES ARE HEREBY EXPRESSLY DISCLAIMED. SKYWORKS DOES NOT WARRANT THE ACCURACY OR COMPLETENESS OF THE INFORMATION, TEXT, GRAPHICS OR OTHER ITEMS CONTAINED WITHIN THESE MATERIALS. SKYWORKS SHALL NOT BE LIABLE FOR ANY DAMAGES, INCLUDING BUT NOT LIMITED TO ANY SPECIAL, INDIRECT, INCIDENTAL, STATUTORY, OR CONSEQUENTIAL DAMAGES, INCLUDING WITHOUT LIMITATION, LOST REVENUES OR LOST PROFITS THAT MAY RESULT FROM THE USE OF THE MATERIALS OR INFORMATION, WHETHER OR NOT THE RECIPIENT OF MATERIALS HAS BEEN ADVISED OF THE POSSIBILITY OF SUCH DAMAGE.

Skyworks products are not intended for use in medical, lifesaving or life-sustaining applications, or other equipment in which the failure of the Skyworks products could lead to personal injury, death, physical or environmental damage. Skyworks customers using or selling Skyworks products for use in such applications do so at their own risk and agree to fully indemnify Skyworks for any damages resulting from such improper use or sale.

Customers are responsible for their products and applications using Skyworks products, which may deviate from published specifications as a result of design defects, errors, or operation of products outside of published parameters or design specifications. Customers should include design and operating safeguards to minimize these and other risks. Skyworks assumes no liability for applications assistance, customer product design, or damage to any equipment resulting from the use of Skyworks products outside of Skyworks' published specifications or parameters.

Skyworks, the Skyworks symbol, Sky5®, SkyOne®, SkyBlue™, Skyworks Green™, ClockBuilder®, DSPLL®, ISOModem®, ProSLIC®, SiPHY®, and RFeIC® are trademarks or registered trademarks of Skyworks Solutions, Inc. or its subsidiaries in the United States and other countries. Third-party brands and names are for identification purposes only and are the property of their respective owners. Additional information, including relevant terms and conditions, posted at www.skyworksinc.com, are incorporated by reference.