

DATA SHEET

# SKY67181-396LF: 2300 to 6000 MHz Broadband Low-Noise Amplifier

## Applications

- 4G LTE and 5G NR systems
- Active antenna array and massive MIMO
- Receive LNA for micro cell, macro cell, and small cell base stations
- Land mobile radios and military communications
- Low-noise broadband gain block and driver amplifier

## Features

- High gain performance: 22 dB
- Low-noise amplifier:
  - Very low noise figure
  - Temperature and process-stable active bias up to +115 °C
  - Wide operating voltage range
  - Low gain slope over operating band
  - Excellent input return loss
- Integrated controller:
  - Stable amplifier bias
  - Temperature compensation
  - True logic level thresholds
  - Fast response time
- Excellent broadband flat gain performance
- Minimal BOM count
- Low current I<sub>DD</sub> 48 mA @ 5 V
- Fast rise / fall time ENABLE function suitable for TDD application
- Miniature DFN (8-pin, 2 x 2 mm) package (MSL1 @ 260 °C per JEDEC J-STD-020)



Skyworks Green™ products are compliant with all applicable legislation and are halogen-free. For additional information, refer to *Skyworks Definition of Green™*, document number SQ04-0074.

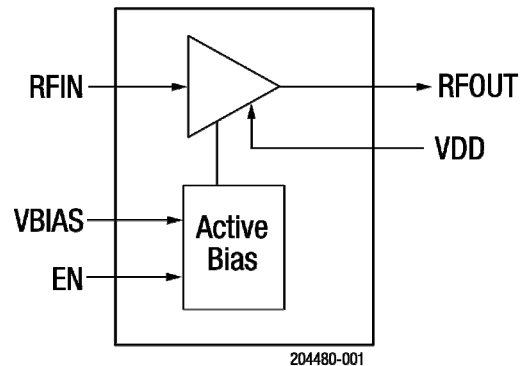

Figure 1. SKY67181-396LF Block Diagram

## Description

The SKY67181-396LF is a wide-band low-noise amplifier with superior gain flatness and exceptional linearity.

The compact 2 x 2 mm, 8-pin Dual Flat No Lead packaged LNA is designed for 4G LTE and 5G NR infrastructure systems operating from 2300 to 6000 MHz.

The internal active bias circuitry provides stable performance over temperature and process variation.

A functional block diagram is shown in Figure 1. The pin configuration and package are shown in Figure 2. Signal pin assignments and functional pin descriptions are provided in Table 1.

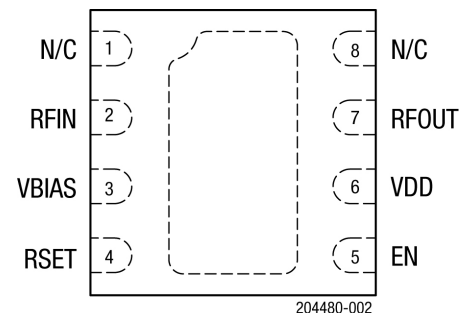

Figure 2. SKY67181-396LF Pinout (Top View)

**Table 1. SKY67181-396LF Signal Descriptions**

Pin	Name	Description	Pin	Name	Description
1	N/C	No connection (may be connected to ground with no change in performance)	5	EN	Enable voltage to LNA
2	RFIN	RF input (DC blocking capacitor required)	6	VDD	VDD voltage to LNA
3	VBIAS	Bias voltage for input gate	7	RFOUT	RF output. DC blocking capacitor is required.
4	RSET	External resistor to set bias current	8	N/C	No connection (may be connected to ground with no change in performance)

**Electrical and Mechanical Specifications**

The absolute maximum ratings of the SKY67181-396LF are provided in Table 2. Recommended operating conditions are shown in Table 3.

Thermal data is shown in Table 4, electrical specifications are provided in the tables that follow.

**Table 2. SKY67181-396LF Absolute Maximum Ratings<sup>1</sup>**

Parameter	Symbol	Minimum	Maximum	Units
Supply voltage	VDD		5.5	V
LNA enable	EN	-0.5	2.8	V
RF input power (C/W)	PIN		+22	dBm
RF input power (LTE 20 MHz, 7.5 dB PAR signal at 105 °C)	PIN		+17	dBm
Storage temperature	TSTG	-40	+150	°C
Operating temperature	TA	-40	+115	°C
Junction temperature	TJ		+150	°C
Electrostatic discharge:	ESD			
Charged Device Model (CDM), Class C3			1000	V
Human Body Model (HBM), Class 1A			250	V

<sup>1</sup> Exposure to maximum rating conditions for extended periods may reduce device reliability. There is no damage to device with only one parameter set at the limit and all other parameters set at or below their nominal value. Exceeding any of the limits listed here may result in permanent damage to the device.

**ESD HANDLING:** Industry-standard ESD handling precautions must be adhered to at all times to avoid damage to this device.

**Table 3. SKY67181-396LF Recommended Operating Conditions**

Parameter	Symbol	Min	Typ	Max	Units
Supply voltage	VDD	3.30	5.00	5.25	V
LNA enable:					
ON	EN		0.00	0.63	V
OFF		1.17	1.80	2.40	V

**Table 4. SKY67181-396LF Electrical Specifications: Thermal Data<sup>1</sup>**  
**(VDD = 5.0 V, Enable = GND, TA = +25 °C, PIN = No RF, Characteristic Impedance [Zo] = 50 ohms, Unless Otherwise Noted)**

Parameter	Symbol	Test Condition	Min	Typ	Max	Units
Thermal resistance	θJC			86.3		°C/W
Channel temperature @ +115 °C reference (package heat slug)	TJ	VDD = 5.0 V, IDD = 55.2 mA, RF applied, dissipated power = 0.28 W		138.8		°C

<sup>1</sup> Performance is guaranteed only under the conditions listed in this table.

**Table 5. SKY67181-396LF Electrical Specifications: 3300 to 4200 MHz<sup>1</sup>**  
**(VDD = 5.0 V, Enable = GND, TA = +25 °C, PIN = -20 dBm, Characteristic Impedance [Zo] = 50 ohms, Unless Otherwise Noted)**

Parameter	Symbol	Test Condition	Min	Typ	Max	Units
<b>RF Specifications</b>						
Noise figure	NF	@ 3300 MHz @ 3800 MHz @ 4200 MHz		0.53 0.58 0.65	1.0 1.0	dB dB dB
Small signal gain	IS21I	@ 3300 MHz @ 3800 MHz @ 4200 MHz	20.0 20.0	22.7 22.5 21.3		dB dB dB
Input return loss	IS11I	@ 3300 MHz @ 3800 MHz @ 4200 MHz	10.0 10.0	11.1 18.1 20.1		dB dB dB
Output return loss	IS22I	@ 3300 MHz @ 3800 MHz @ 4200 MHz	8.5 10.0	10.0 23.2 8.6		dB dB dB
Reverse isolation	IS12I	@ 3300 MHz @ 3800 MHz @ 4200 MHz	33.0 32.0	38.6 38.2 38.8		dB dB dB
Third order output intercept (-20 dBm input/1 MHz tone)	OIP3	@ 3300 MHz @ 3800 MHz @ 4200 MHz	27.0 27.0	28.3 28.6 27.5		dBm dBm dBm
1 dB output compression point	OP1dB	@ 3300 MHz @ 3800 MHz @ 4200 MHz	17.0 17.0	18.3 18.3 16.3		dBm dBm dBm
<b>DC Specifications</b>						
Quiescent current	IDD		35.0	47.3	65.0	mA
Settling time 0.3 dB <sup>2</sup>	TS1	@ 3800 MHz		0.22	0.8	us
Settling time 0.1 dB <sup>3</sup>	TS2	@ 3800 MHz		0.23	0.8	us

<sup>1</sup> Performance is guaranteed only under the conditions listed in this table.

<sup>2</sup> Settling time 0.3 dB is measured from the time the LNA enable reaches 50% of LNA enable "on" level to the time at which the RF output power achieves within 0.3 dB of the average steady-state "on" level.

<sup>3</sup> Settling time 0.1 dB is measured from the time the LNA enable reaches 50% of LNA enable "on" level to the time at which the RF output power achieves within 0.1 dB of the average steady-state "on" level.

### Typical Performance Characteristics

3300 to 4200 MHz, (VDD = 5 V, TA = +25 °C, P<sub>IN</sub> = -20 dBm, Characteristic Impedance (Z<sub>o</sub>) = 50 Ohms, Unless Otherwise Noted)

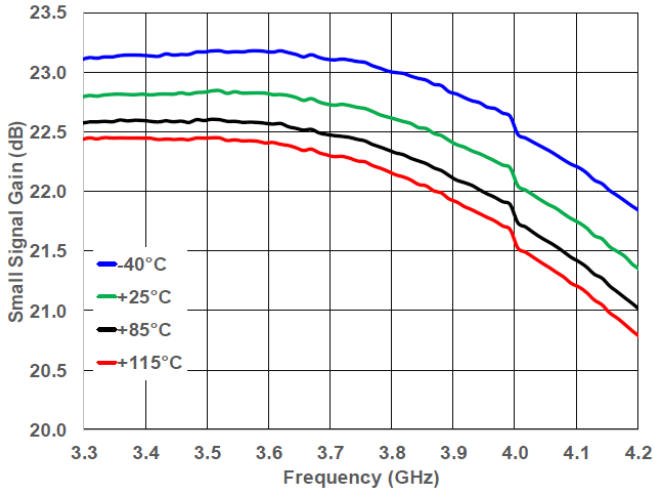

Figure 3. Small Signal Gain (dB) vs Frequency (GHz)

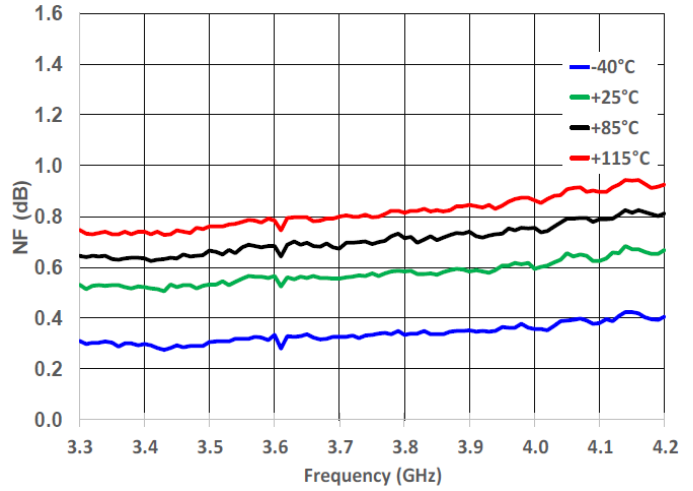

Figure 4. Noise Figure (dB) vs Frequency (GHz)

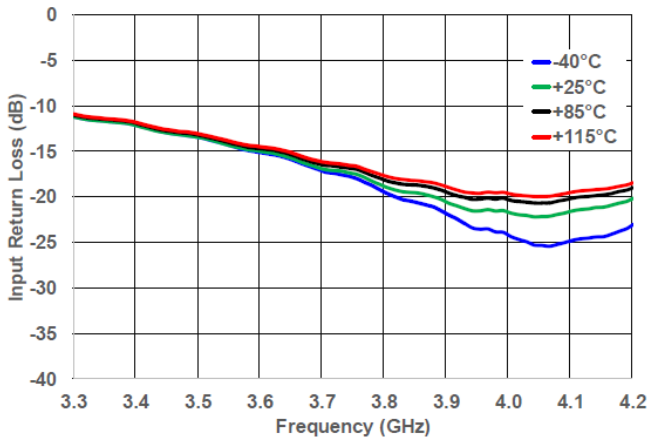

Figure 5. Input Return Loss (dB) vs Frequency

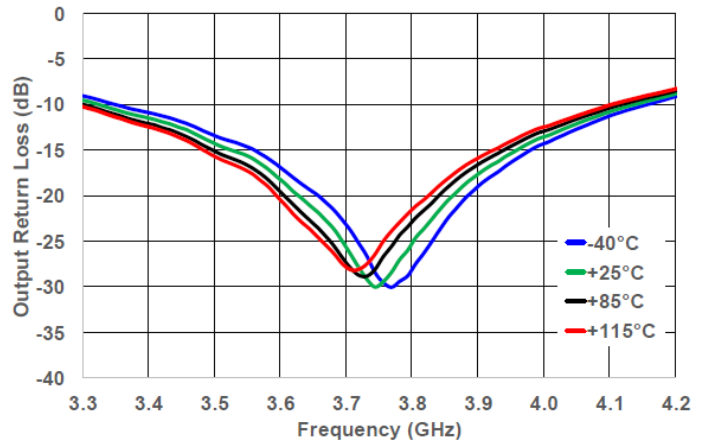

Figure 6. Output Return Loss (dB) vs Frequency

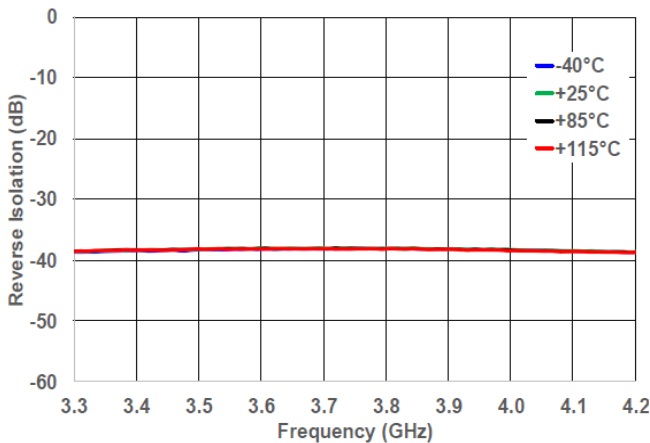

Figure 7. Reverse Isolation (dB) vs Frequency (GHz)

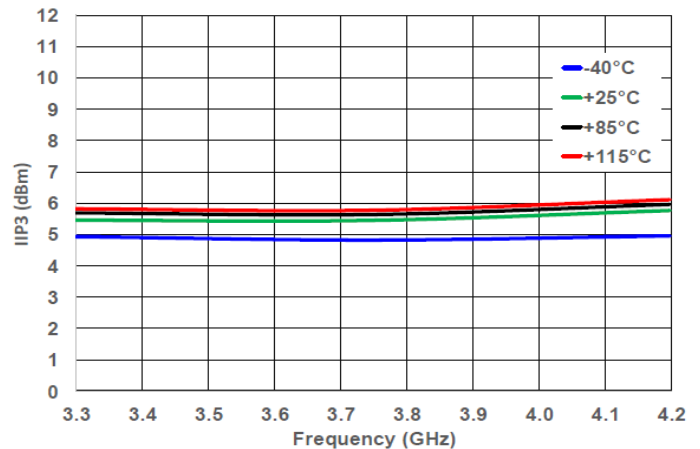

Figure 8. IIP3 (dBm) vs Frequency (GHz)

### Typical Performance Characteristics

3300 to 4200 MHz, (VDD = 5 V, TA = +25 °C, P<sub>IN</sub> = -20 dBm, Characteristic Impedance (Z<sub>o</sub>) = 50 Ohms, Unless Otherwise Noted)

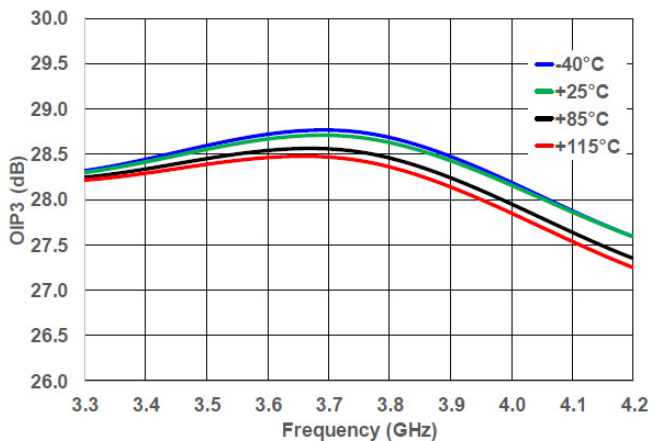

Figure 9. OIP3 (dBm) vs Frequency (GHz)

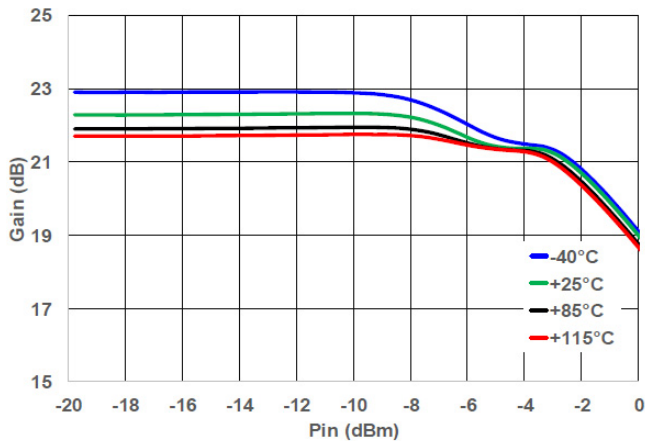

Figure 10. Gain (dB) vs PIN (dBm)

0 to 20 GHz, (VDD = 5 V, TA = +25 °C, P<sub>IN</sub> = -20 dBm, Characteristic Impedance (Z<sub>o</sub>) = 50 Ohms)

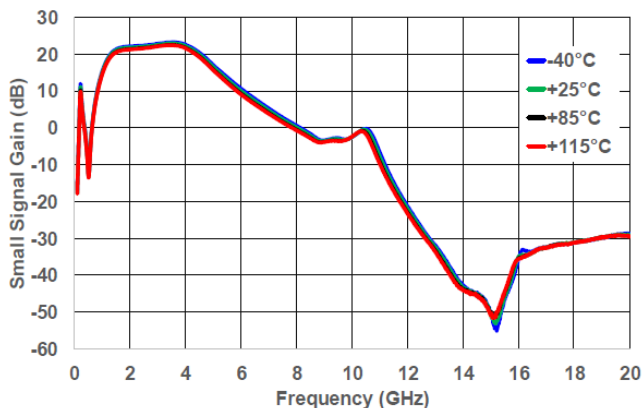

Figure 11. Small Signal Gain (dB) vs Frequency (GHz)

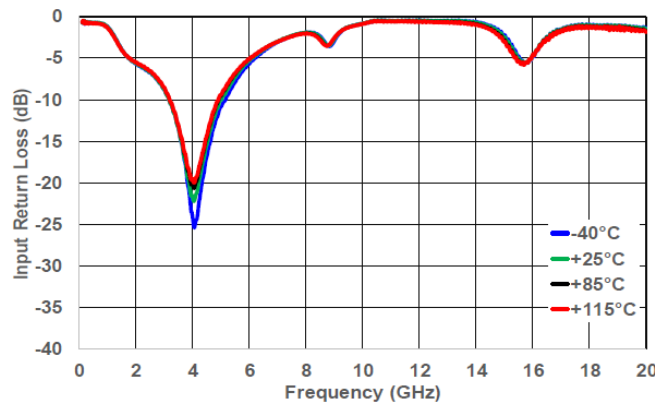

Figure 12. Input Return Loss (dB) vs Frequency (GHz)

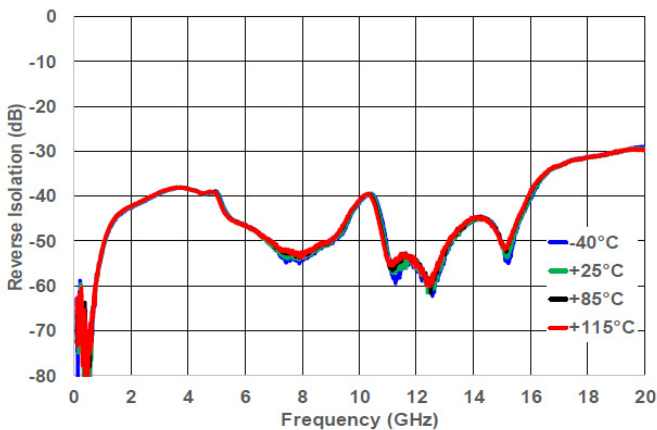

Figure 13. Reverse Isolation (dB) vs Frequency (GHz)

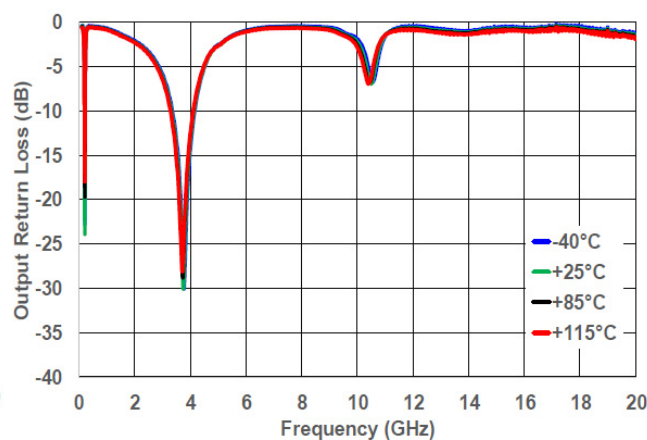

Figure 14. Output Return Loss (dB) vs Frequency (GHz)

### Typical Performance Characteristics

0 to 20 GHz, (VDD = 5 V, TA = +25 °C, PIN = -20 dBm, Characteristic Impedance (Zo) = 50 Ohms, Unless Otherwise Noted)

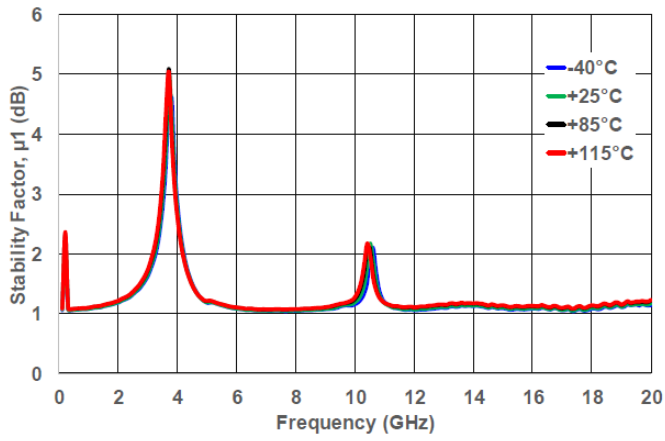

Figure 15. Stability Factor,  $\mu_1$  (dB) vs Frequency (GHz)

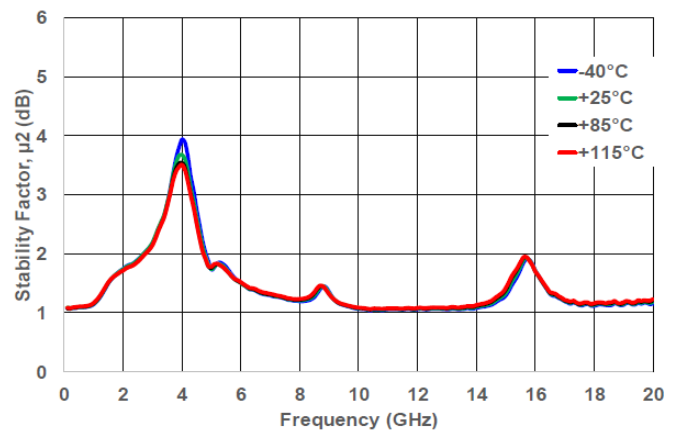

Figure 16. Stability Factor,  $\mu_2$  (dB) vs Frequency (GHz)

**Table 6. SKY67181-396LF Electrical Specifications: 4400 to 5000 MHz<sup>1</sup>**  
**(VDD = 5.0 V, Enable = GND, TA = +25 °C P<sub>IN</sub> = -20 dBm, Characteristic Impedance [Z<sub>0</sub>] = 50 Ohms, Unless Otherwise Noted)**

Parameter	Symbol	Test Condition	Min	Typ	Max	Units
<b>RF Specifications</b>						
Noise figure	NF	@ 4400 MHz		0.62	1	dB
		@ 4700 MHz		0.63	1	dB
		@ 5000 MHz		0.72	1	dB
Gain	IS21I	@ 4400 MHz	18.5	20.4		dB
		@ 4700 MHz	18.5	20.7		dB
		@ 5000 MHz	18.5	20.2		dB
Input return loss	IS11I	@ 4400 MHz	10	15.0		dB
		@ 4700 MHz	10	16.1		dB
		@ 5000 MHz	9	17.5		dB
Output return loss	IS22I	@ 4400 MHz	9	16.3		dB
		@ 4700 MHz	8	27.9		dB
		@ 5000 MHz	8	13.3		dB
Reverse isolation	IS12I	@ 4400 MHz		38.5		dB
		@ 4700 MHz		37.2		dB
		@ 5000 MHz		35.8		dB
Third order output intercept (-20 dBm input/1 MHz tone)	OIP3	@ 4400 MHz	25	27.8		dBm
		@ 4700 MHz	24	26.5		dBm
		@ 5000 MHz	24	25.6		dBm
1 dB output compression point	OP1dB	@ 4400 MHz	15	17.3		dBm
		@ 4700 MHz	15	17.6		dBm
		@ 5000 MHz	13	15.1		dBm
<b>DC Specifications</b>						
Quiescent current	IDD			47.9		mA
Settling time 0.3 dB <sup>2</sup>	TS1			0.18		us
Settling time 0.1 dB <sup>3</sup>	TS2	@ 4700 MHz		0.20		us

<sup>1</sup> Verified by characterization.

<sup>2</sup> Settling time 0.3 dB is measured from the time the LNA enable reaches 50% of LNA enable "on" level to the time at which the RF output power achieves within 0.3 dB of the average steady-state "on" level.

<sup>3</sup> Settling time 0.1 dB is measured from the time the LNA enable reaches 50% of LNA enable "on" level to the time at which the RF output power achieves within 0.1 dB of the average steady-state "on" level.

## Typical Performance Characteristics

4400 to 5000 MHz, (VDD = 5 V, TA = +25 °C, PIN = -20 dBm, Characteristic Impedance (Zo) = 50 Ohms, Unless Otherwise Noted)

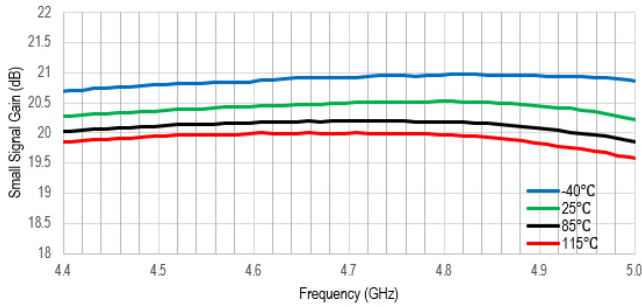

Figure 17. Small Signal Gain (dB) vs Frequency (GHz)

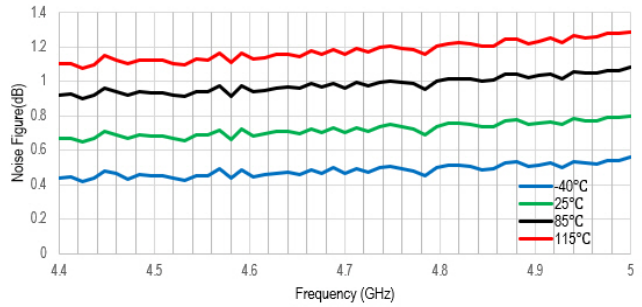

Figure 18. Noise Figure (dB) vs Frequency (GHz)

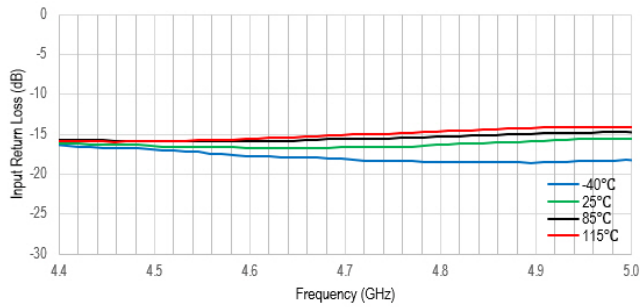

Figure 19. Input Return Loss (dB) vs Frequency

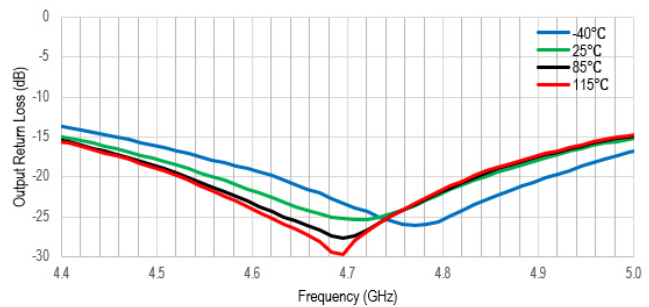

Figure 20. Output Return Loss (dB) vs Frequency

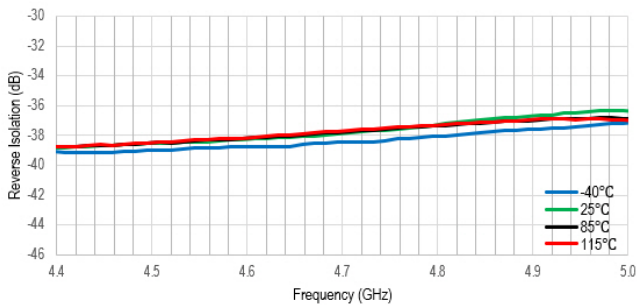

Figure 21. Reverse Isolation (dB) vs Frequency (GHz)

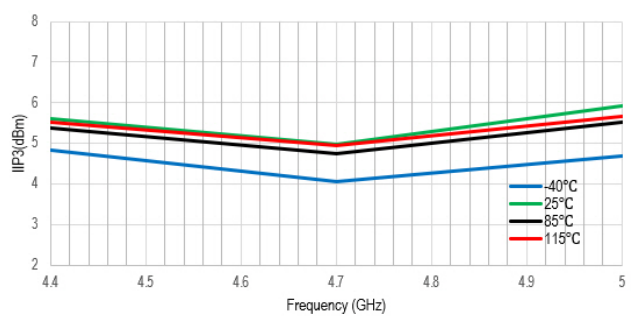

Figure 22. IIP3 (dBm) vs Frequency (GHz)



### Typical Performance Characteristics

4400 to 5000 MHz, (VDD = 5 V, TA = +25 °C, P<sub>IN</sub> = -20 dBm, Characteristic Impedance (Z<sub>o</sub>) = 50 Ohms, Unless Otherwise Noted)

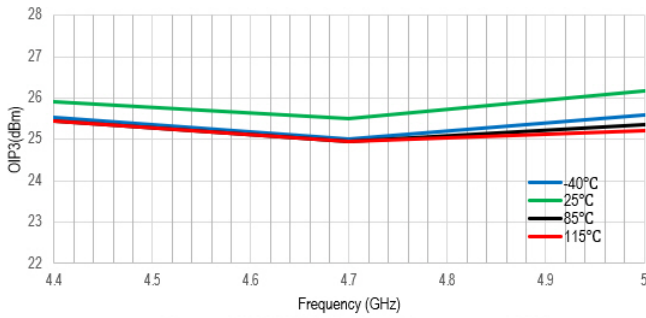

Figure 23. OIP3 (dBm) vs Frequency (GHz)

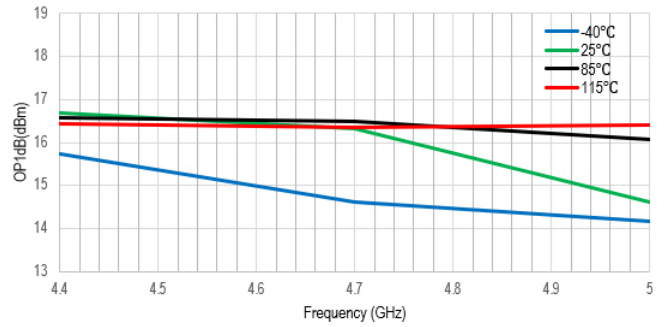

Figure 24. OP1dB (dBm) vs Frequency (GHz)

0 to 20 GHz, (VDD = 5 V, TA = +25 °C, P<sub>IN</sub> = -20 dBm, Characteristic Impedance (Z<sub>o</sub>) = 50 Ohms)

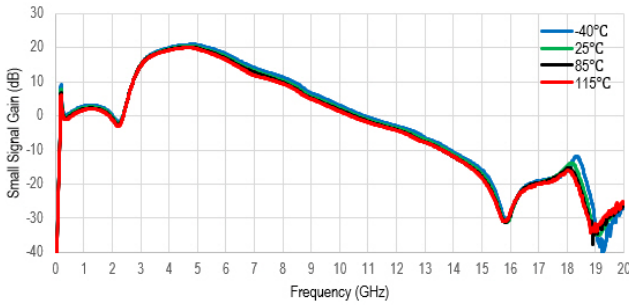

Figure 25. Small Signal Gain (dB) vs Frequency (GHz)

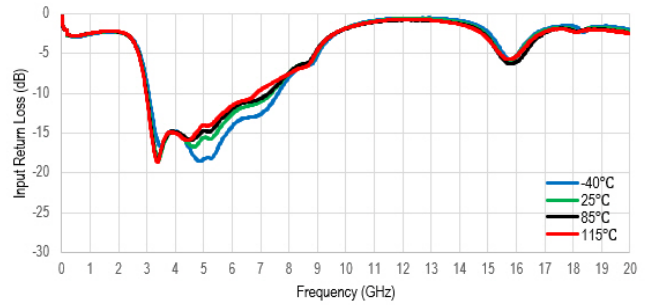

Figure 26. Input Return Loss (dB) vs Frequency (GHz)

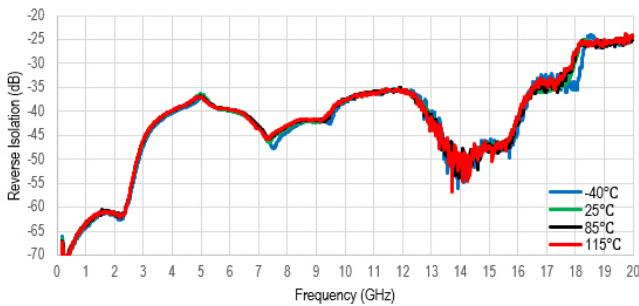

Figure 27. Reverse Isolation (dB) vs Frequency (GHz)

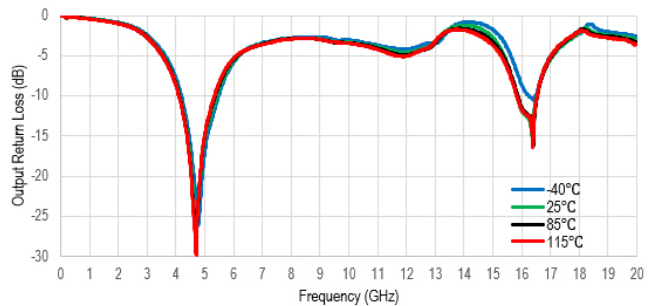
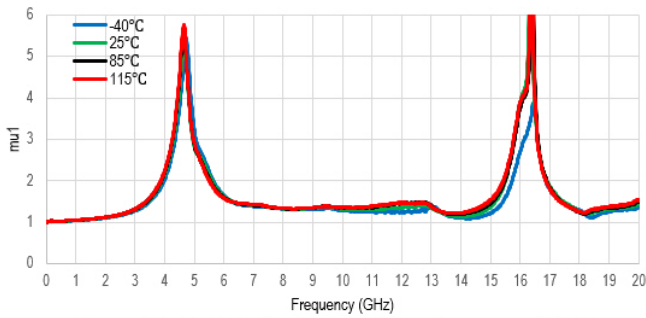

Figure 28. Output Return Loss (dB) vs Frequency (GHz)

### Typical Performance Characteristics

0 to 20 GHz, (VDD = 5 V, TA = +25 °C, PIN = -20 dBm, Characteristic Impedance (Zo) = 50 Ohms, Unless Otherwise Noted)



**Figure 29. Stability Factor,  $\mu_1$  (dB) vs Frequency (GHz)**

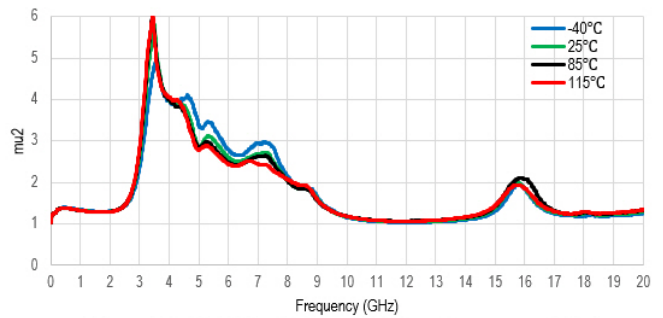

**Figure 30. Stability Factor,  $\mu_2$  (dB) vs Frequency (GHz)**

**Table 7. SKY67181-396LF Electrical Specifications: 2300 to 2700 MHz<sup>1</sup>**  
**(VDD = 5.0 V, Enable = GND, TA = +25 °C, P<sub>IN</sub> = -20 dBm, Characteristic Impedance [Z<sub>0</sub>] = 50 ohms, Unless Otherwise Noted)**

Parameter	Symbol	Test Condition	Min	Typ	Max	Units
<b>RF Specifications</b>						
Noise figure	NF	@ 2300 MHz		0.47	0.85	dB
		@ 2500 MHz		0.48	0.85	dB
		@ 2700 MHz		0.49	0.90	dB
Small signal gain	IS21I	@ 2300 MHz	24.0	25.4		dB
		@ 2500 MHz	23.5	25.0		dB
		@ 2700 MHz	22.5	24.3		dB
Input return loss	IS11I	@ 2300 MHz	10.0	16.5		dB
		@ 2500 MHz	10.0	25.9		dB
		@ 2700 MHz	10.0	27.4		dB
Output return loss	IS22I	@ 2300 MHz	10.0	16.0		dB
		@ 2500 MHz	10.0	29.7		dB
		@ 2700 MHz	9.0	13.2		dB
Reverse isolation	IS12I	@ 2300 MHz		37.7		dB
		@ 2500 MHz		37.7		dB
		@ 2700 MHz		38.0		dB
Third order output intercept (-20 dBm input/1 MHz tone)	OIP3	@ 2300 MHz	25.5	28.4		dBm
		@ 2500 MHz	26.0	28.9		dBm
		@ 2700 MHz	26.0	29.1		dBm
1 dB output compression point	OP1dB	@ 2300 MHz	16.5	17.9		dBm
		@ 2500 MHz	15.5	17.2		dBm
		@ 2700 MHz	15.0	17.0		dBm
<b>DC Specifications</b>						
Quiescent current	I <sub>DD</sub>			49.00		mA
Settling time 0.3 dB <sup>2</sup>	T <sub>S1</sub>			0.17	0.80	us
Settling time 0.1 dB <sup>3</sup>	T <sub>S2</sub>	@ 2700 MHz		0.20	0.80	us

<sup>1</sup> Verified by characterization.

<sup>2</sup> Settling time 0.3 dB is measured from the time the LNA enable reaches 50% of LNA enable "on" level to the time at which the RF output power achieves within 0.3 dB of the average steady-state "on" level.

<sup>3</sup> Settling time 0.1 dB is measured from the time the LNA enable reaches 50% of LNA enable "on" level to the time at which the RF output power achieves within 0.1 dB of the average steady-state "on" level.

### Typical Performance Characteristics

2300 to 2700 MHz, (VDD = 5 V, TA = +25 °C, P<sub>IN</sub> = -20 dBm, Characteristic Impedance (Z<sub>o</sub>) = 50 Ohms, Unless Otherwise Noted)

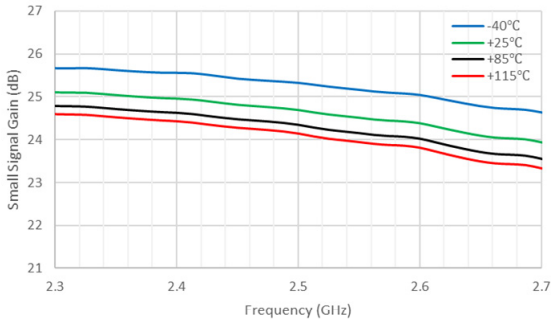

Figure 31. Small Signal Gain (dB) vs Frequency (GHz)

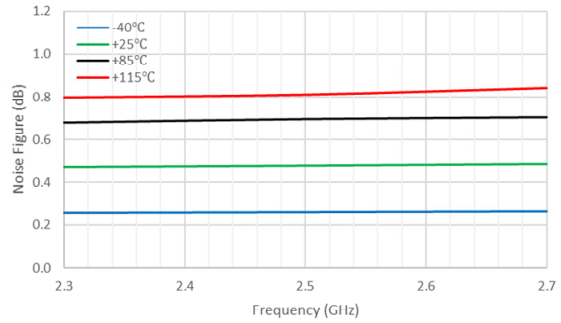

Figure 32. Noise Figure (dB) vs Frequency (GHz)

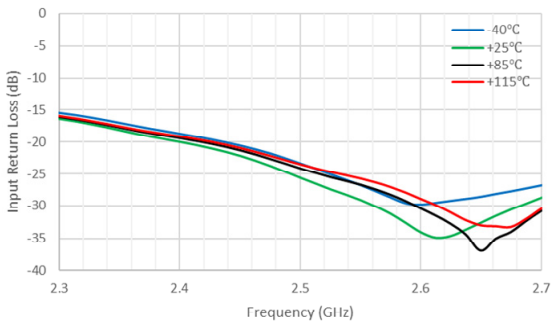

Figure 33. Input Return Loss (dB) vs Frequency

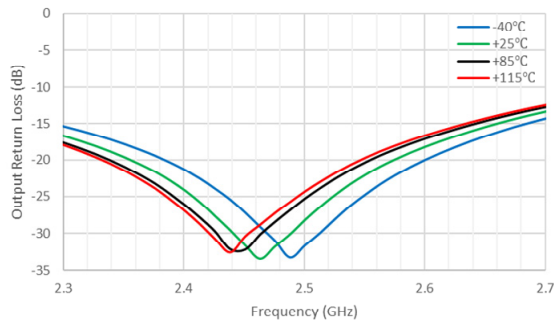

Figure 34. Output Return Loss (dB) vs Frequency

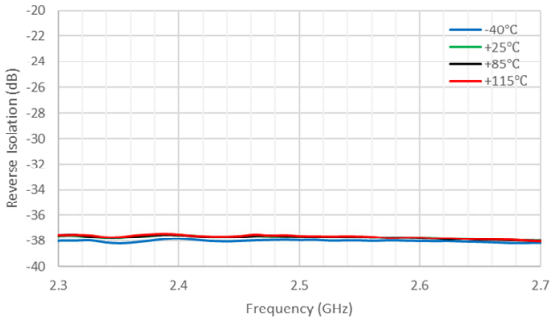

Figure 35. Reverse Isolation (dB) vs Frequency (GHz)

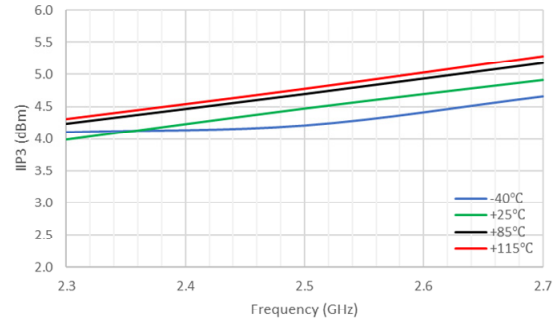

Figure 36. IIP3 (dBm) vs Frequency (GHz)

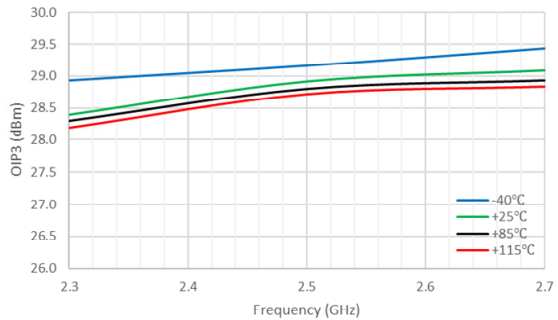

Figure 37. OIP3 (dBm) vs Frequency (GHz)

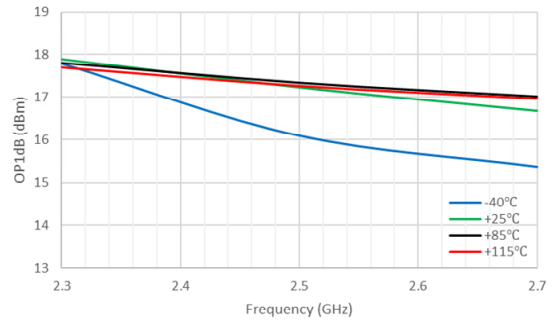

Figure 38. OP1dB (dBm) vs Frequency (GHz)

### Typical Performance Characteristics

0 to 20 GHz, (VDD = 5 V, TA = +25 °C, P<sub>IN</sub> = -20 dBm, Characteristic Impedance (Z<sub>0</sub>) = 50 Ohms, Unless Otherwise Noted)

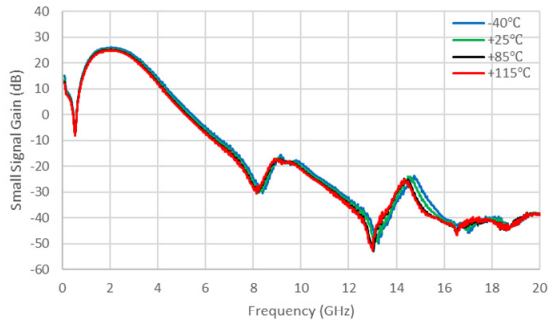

Figure 39. Small Signal Gain (dB) vs Frequency (GHz)

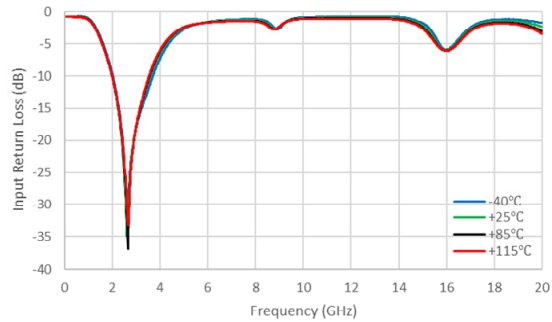

Figure 40. Input Return Loss (dB) vs Frequency (GHz)

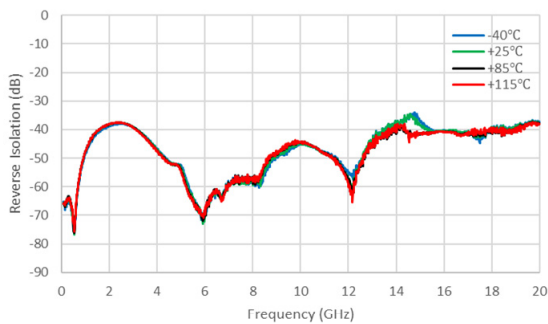

Figure 41. Reverse Isolation (dB) vs Frequency (GHz)

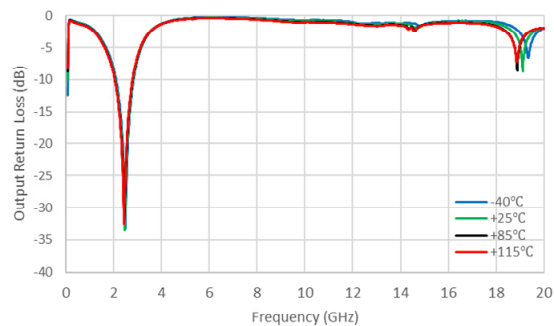

Figure 42. Output Return Loss (dB) vs Frequency (GHz)

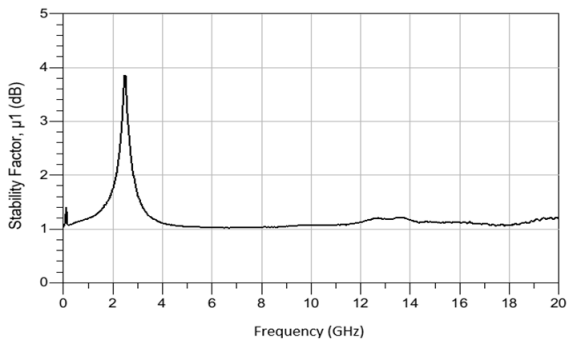

Figure 43. Stability Factor,  $\mu_1$  (dB) vs Frequency (GHz) at -40 °C

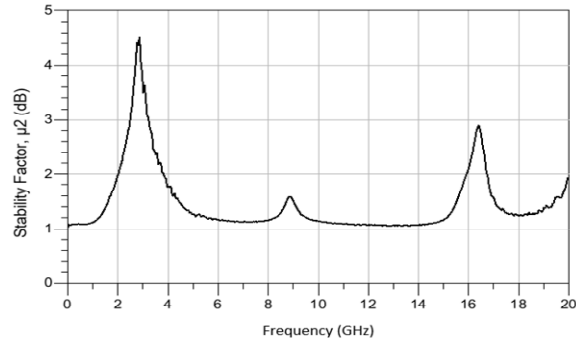

Figure 44. Stability Factor,  $\mu_2$  (dB) vs Frequency (GHz) at -40 °C

**Table 8. SKY67181-396LF Electrical Specifications: 5000 to 5800 MHz<sup>1</sup>**  
**(VDD = 5.0 V, Enable = GND, TA = +25 °C, P<sub>IN</sub> = -20 dBm, Characteristic Impedance [Z<sub>0</sub>] = 50 ohms, Unless Otherwise Noted)**

Parameter	Symbol	Test Condition	Min	Typ	Max	Units
<b>RF Specifications</b>						
Noise figure	NF	@ 5000 MHz		0.79	1.1	dB
		@ 5400 MHz		0.89	1.1	dB
		@ 5800 MHz		1.05	1.3	dB
Gain	IS21I	@ 5000 MHz	17.5	19.1		dB
		@ 5400 MHz	17.5	18.8		dB
		@ 5800 MHz	17.5	18.6		dB
Input return loss	IS11I	@ 5000 MHz	8	10.8		dB
		@ 5400 MHz	8	13.6		dB
		@ 5800 MHz	8	14.1		dB
Output return loss	IS22I	@ 5000 MHz	10	17.4		dB
		@ 5400 MHz	10	21.2		dB
		@ 5800 MHz	8	11.2		dB
Reverse isolation	IS12I	@ 5000 MHz		37.3		dB
		@ 5400 MHz		39.0		dB
		@ 5800 MHz		39.6		dB
Third order output intercept (-20 dBm input/1 MHz tone)	OIP3	@ 5000 MHz	22	24.0		dBm
		@ 5400 MHz	21	23.3		dBm
		@ 5800 MHz	21	22.6		dBm
1 dB output compression point	OP1dB	@ 5000 MHz	12	14.3		dBm
		@ 5400 MHz	10	12.7		dBm
		@ 5800 MHz	10	11.1		dBm
<b>DC Specifications</b>						
Quiescent current	I <sub>DD</sub>			50.0		mA
Settling time 0.3 dB <sup>2</sup>	T <sub>S1</sub>			0.18		us
Settling time 0.1 dB <sup>3</sup>	T <sub>S2</sub>	@ 5400 MHz		0.20		us

<sup>1</sup> Verified by characterization.

<sup>2</sup> Settling time 0.3 dB is measured from the time the LNA enable reaches 50% of LNA enable "on" level to the time at which the RF output power achieves within 0.3 dB of the average steady-state "on" level.

<sup>3</sup> Settling time 0.1 dB is measured from the time the LNA enable reaches 50% of LNA enable "on" level to the time at which the RF output power achieves within 0.1 dB of the average steady-state "on" level.

### Typical Performance Characteristics

5000 to 5800 MHz, (VDD = 5 V, TA = +25 °C, P<sub>IN</sub> = -20 dBm, Characteristic Impedance (Z<sub>o</sub>) = 50 Ohms, Unless Otherwise Noted)

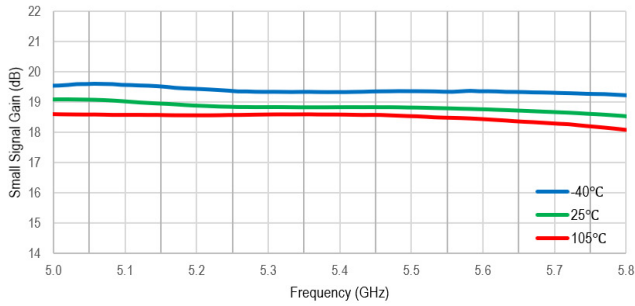

Figure 45. Small Signal Gain (dB) vs Frequency (GHz)

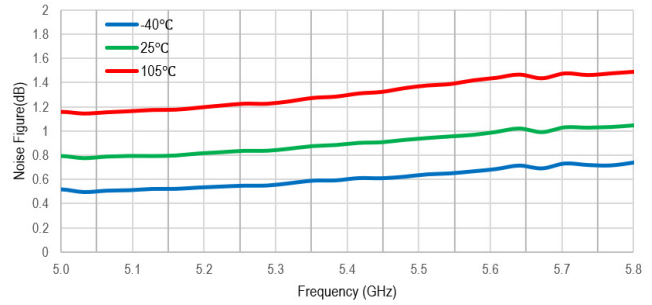

Figure 46. Noise Figure (dB) vs Frequency (GHz)

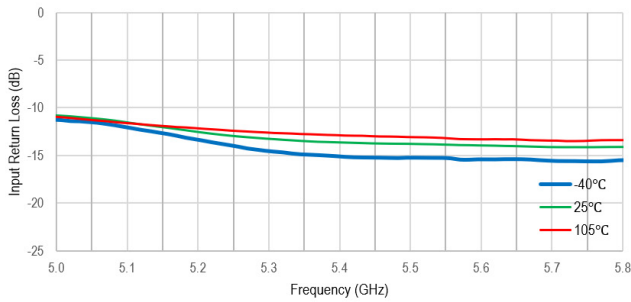

Figure 47. Input Return Loss (dB) vs Frequency

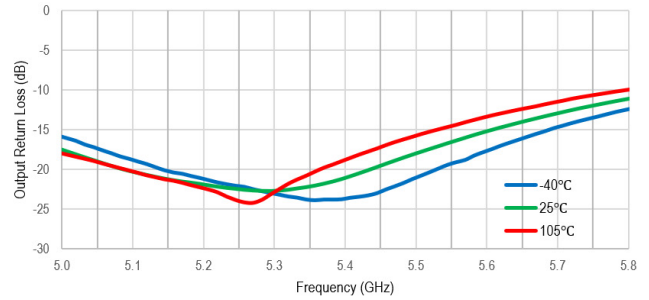

Figure 48. Output Return Loss (dB) vs Frequency

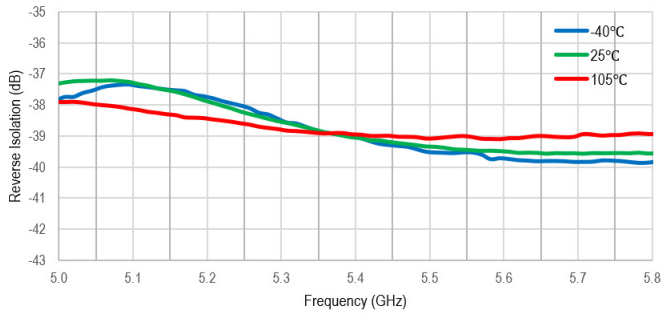

Figure 49. Reverse Isolation (dB) vs Frequency (GHz)

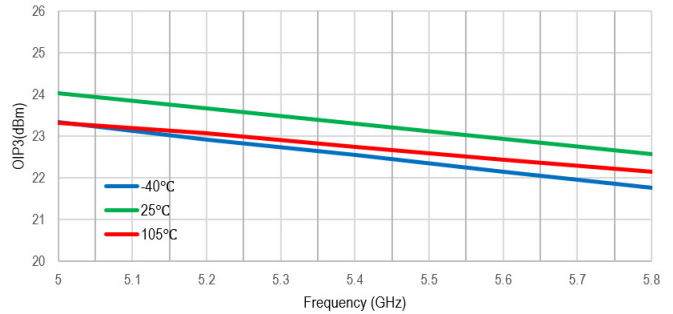

Figure 50. OIP3 (dBm) vs Frequency (GHz)

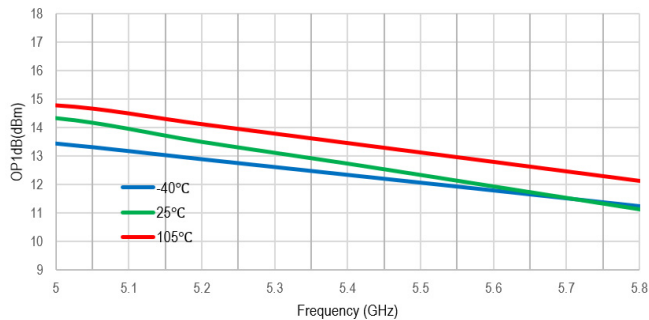

Figure 51. OP1dB (dBm) vs Frequency (GHz)

### Typical Performance Characteristics

0 to 20 GHz, (VDD = 5 V, TA = +25 °C, PIN = -20 dBm, Characteristic Impedance (Zo) = 50 Ohms, Unless Otherwise Noted)

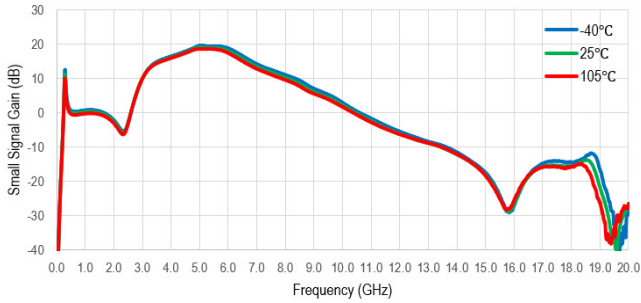

Figure 52. Small Signal Gain (dB) vs Frequency (GHz)

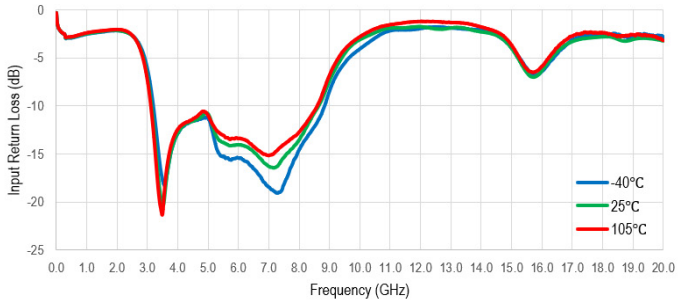

Figure 53. Input Return Loss (dB) vs Frequency (GHz)

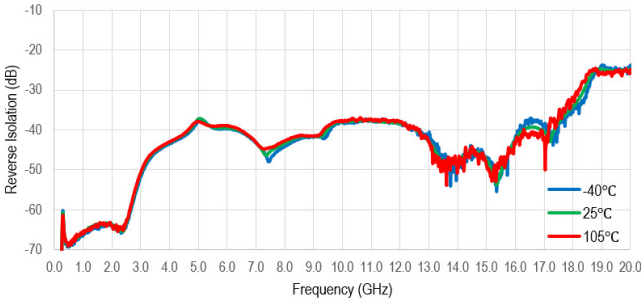

Figure 54. Reverse Isolation (dB) vs Frequency (GHz)

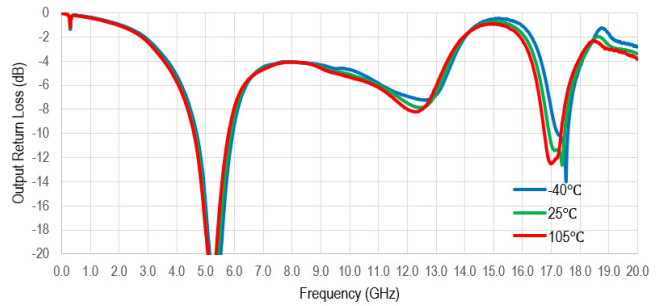

Figure 55. Output Return Loss (dB) vs Frequency (GHz)

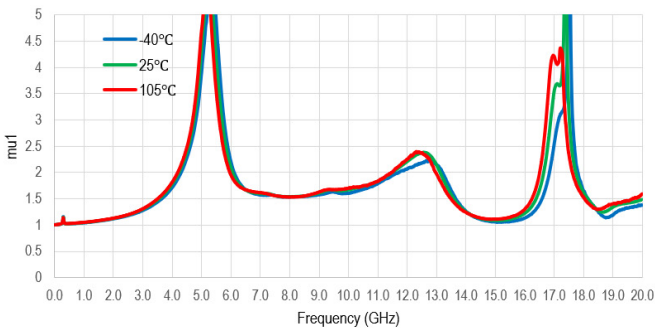

Figure 56. Stability Factor,  $\mu_1$  (dB) vs Frequency (GHz)

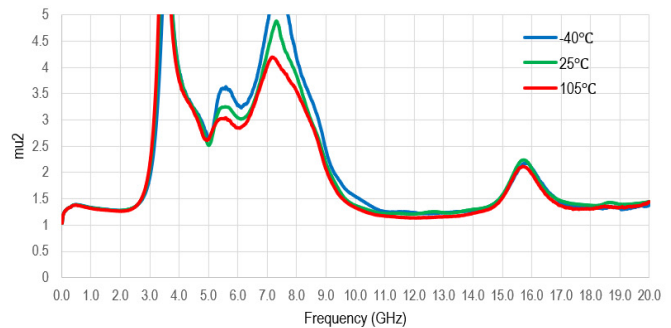

Figure 57. Stability Factor,  $\mu_2$  (dB) vs Frequency (GHz)



### Evaluation Board Description

The SKY67181-396LF Evaluation Board is used to test the performance of the SKY67181-396LF LNA. An Evaluation Board schematic diagram is provided below. Bill of materials (BOM) tables are included for the evaluation boards optimized for 3300 to 4200 MHz, 4400 to 5000 MHz, 2300 to 2700 MHz and 5000 to 5800 MHz.

An evaluation board assembly diagram and layer information is included below.

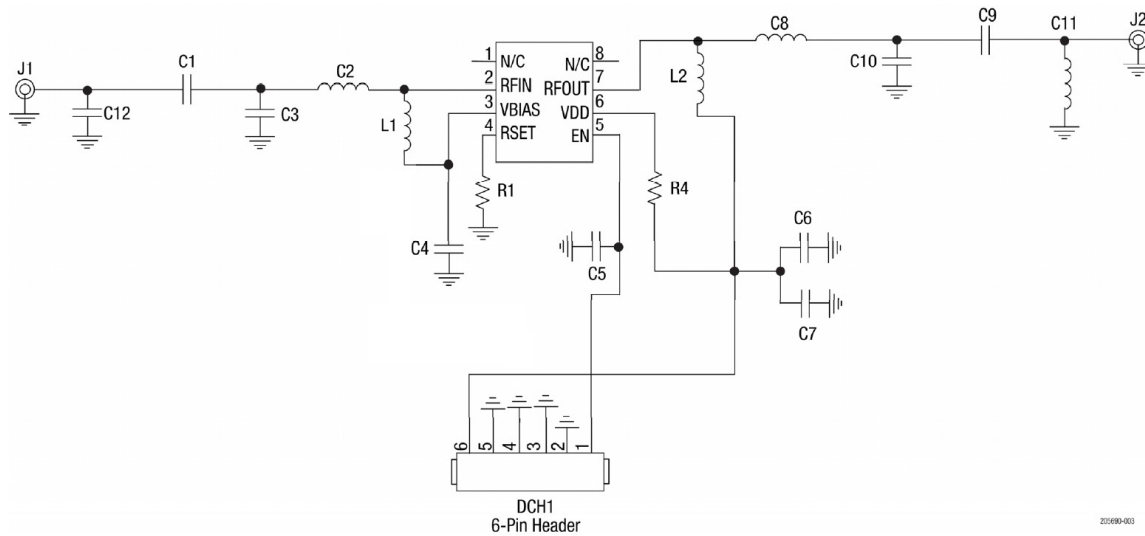

Figure 58. SKY67181-396LF Evaluation Board Schematic

Table 9. SKY67181-396LF Evaluation Board Bill of Materials for 3300 to 4200 MHz Tuning

Component	Value	Size	Part Number
C1, C4	20 pF	0201	GJM0336C1E200GB01
C2	1.4 nH	0201	LQP03HQ1N4B02
C3	0.5 pF	0201	GJM0335C1ER50BB01
C5	20 pF	0201	GRM0335C1H200JA01
C6, C7	0.22 uF	0201	GRM033C80J224ME90D
C8	47 pF	0201	GRM0335C1H470JA01
C9	2.0 nH	0201	LQP03TG2N0B
C10	6.8 nH	0201	LQP03TG6N8H
C11, C12	DNI		
L1	4.7 nH	0201	LQP03HQ4N7H02
L2	4.3 nH	0201	LQP03TG4N3H
R1	11 kohm	0201	ERJ-1GNF1102C
R4	100 ohm	0201	ERJ-1GNJ101C

**Table 10. SKY67181-396LF Evaluation Board Bill of Materials for 4400 to 5000 MHz Tuning**

Component	Value	Size	Number
C1	20 pF	0201	GJM0336C1E200GB01
C2	0.8 nH	0201	LQP03HQ0N8B02
C3	0.4 pF	0201	GJM0335C1ER40BB01
C4	2 pF	0201	GJM0335C1E2R0BB01
C5	20 pF	0201	GRM0335C1H200JA01
C6, C7	0.22 uF	0201	GRM033C80J224ME90D
C8	68 pF	0201	GRM0335C1H680JA01
C9	0 ohm	0201	ERJ-1GN0R00C
C10	0.8 nH	0201	LQP03TG0N8C
C11	300 ohm	0201	ERJ-1GNJ301C
C12	DNI		
L1	2.0 nH	0201	LQP03HQ2N0B02
L2	8.2 nH	0201	LQP03TG8N2H
R1	11 kohm	0201	ERJ-1GNF1102C
R4	100 ohm	0201	ERJ-1GNJ101C

**Table 11. SKY67181-396LF Evaluation Board Bill of Materials for 2300 to 2700 MHz Tuning**

Component	Value	Size	Part Number
C1, C4	20 pF	0201	GJM0336C1E200GB01
C2	2.5 nH	0201	LQP03HQ2N5B
C3	0.3 pF	0201	GJM0335C1ER30BB01
C5	20 pF	0201	GRM0335C1H200JA01
C6, C11, C12	DNI		
C7	0.22 uF	0201	GRM033C80J224ME90D
C8	82 pF	0201	GRM0335C1H820JA01
C9	3.9 nH	0201	LQP03TG3N9C
C10, L2	15 nH	0201	LQP03TG15NJ
L1	4.3 nH	0201	LQP03HQ4N3H
R1	11 kohm	0201	ERJ-1GNF1102C
R4	100 ohm	0201	ERJ-1GNJ101C

**Table 12. SKY67181-396LF Evaluation Board Bill of Materials for 5000 to 5800 MHz Tuning**

Component	Value	Size	Part Number
C1	20 pF	0201	GJM0336C1E200GB01
C2	0.6 nH	0201	LQP03HQ0N6B02
C3	0.4 pF	0201	GJM0335C1R40BB01
C4	2.0 pF		GJM0335C12R0BB01
C5	20 pF	0201	GRM0335C1H200JA01
C6	0.22 uF	0201	GRM033C80J224ME90D
C7	0.22 uF	0201	GRM033C80J224ME90D
C8	68 pF	0201	GRM0335C1H680JA01
C9	0 Ohm	0201	Any
C10	0.8 nH	0201	LQP03TG0N8B02
C11	150 ohm	0201	Any
C12	DNI		
L1	1.8 nH	0201	LQP03HQ1N8B02
L2	2.2 nH	0201	LQP03TN2N2B02
R1	11 kohm	0201	Any
R4	100 ohm	0201	Any

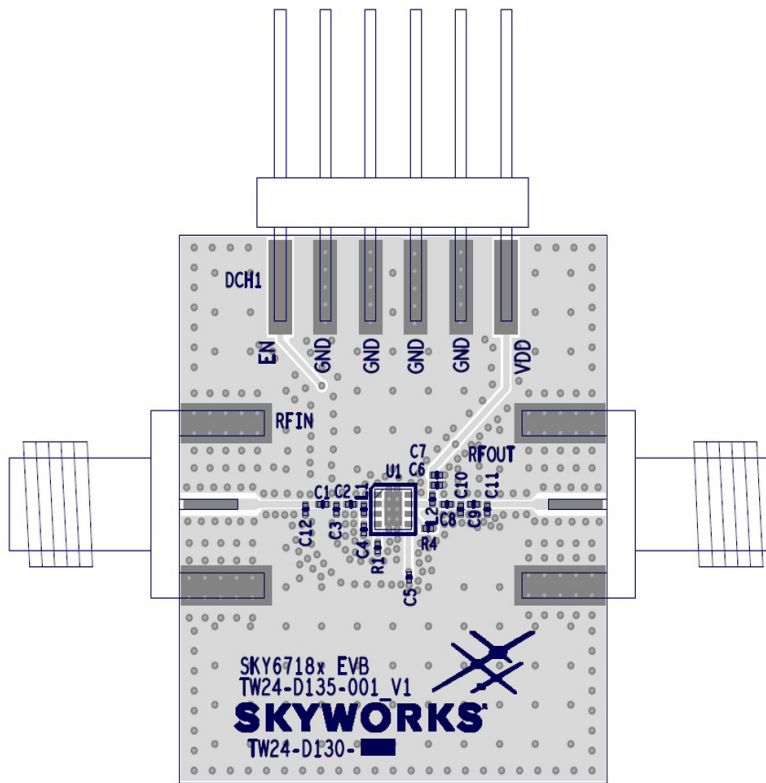

**Figure 59. SKY67181-396LF EVB Assembly Diagram**

50-OHM TRACE	50-OHM TRACE	CROSS SECTION	NAME	THICKNESS	MATERIALS
$W=0.301mm$ $S=0.100mm$	TOL: +/- 5% $W=0.508mm$ $CPW = 0.375mm$		TMASK	0.020mm	SOLDER RESIST
			L1	0.047mm	FINISHED Cu.
$W=N/A$ $S=N/A$	$W=N/A$ $CPW = N/A$		DIELECTRIC	0.254mm	RO4350B
			L2	0.018mm	Cu-0.5oz.
			L3	0.018mm	Cu-0.5oz.
			DIELECTRIC	0.254mm	FR4 (4.34)
			L4	0.047mm	FINISHED Cu.
			BMASK	0.020mm	SOLDER RESIST
<b>TOTAL THICKNESS</b>				<b>1.578mm</b>	<b>TOL: +/- 10%</b>

205690-005

Figure 60. SKY67181-396LF EVB Layer Details

### Package Dimensions

Typical part marking for the SKY67181-396LF is shown below. The PCB layout footprint, package dimensions, and tape and reel dimensions are shown on the following pages.

### Package and Handling Information

Instructions on the shipping container label regarding exposure to moisture after the container seal is broken must be followed. Otherwise, problems related to moisture absorption may occur when the part is subjected to high temperature during solder assembly.

The SKY67181-396LF is rated to Moisture Sensitivity Level 1 (MSL1) at 260 °C. It can be used for lead or lead-free soldering. For additional information, refer to the Skyworks Application Note, *Solder Reflow Information*, document number 200164.

Care must be taken when attaching this product, whether it is done manually or in a production solder reflow environment. Production quantities of this product are shipped in a standard tape and reel format.

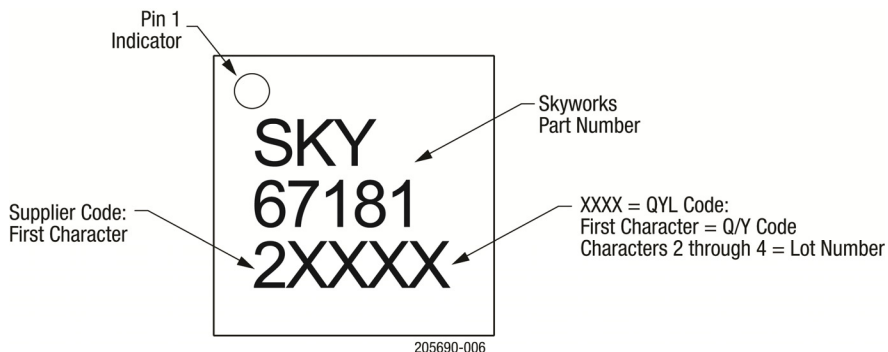

205690-006

Figure 61. SKY67181-396LF Typical Part Marking

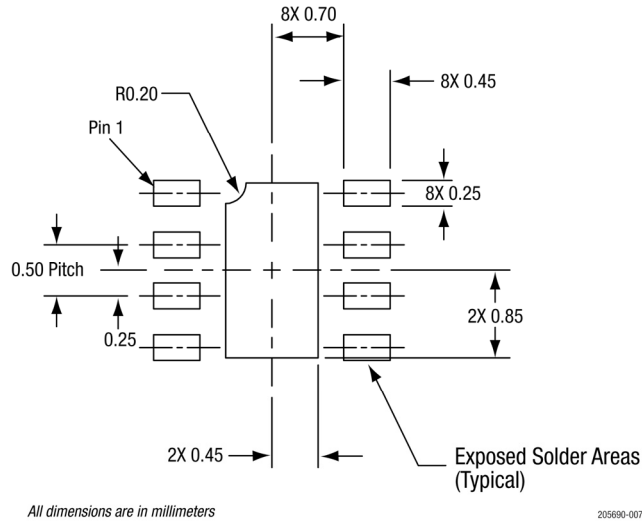
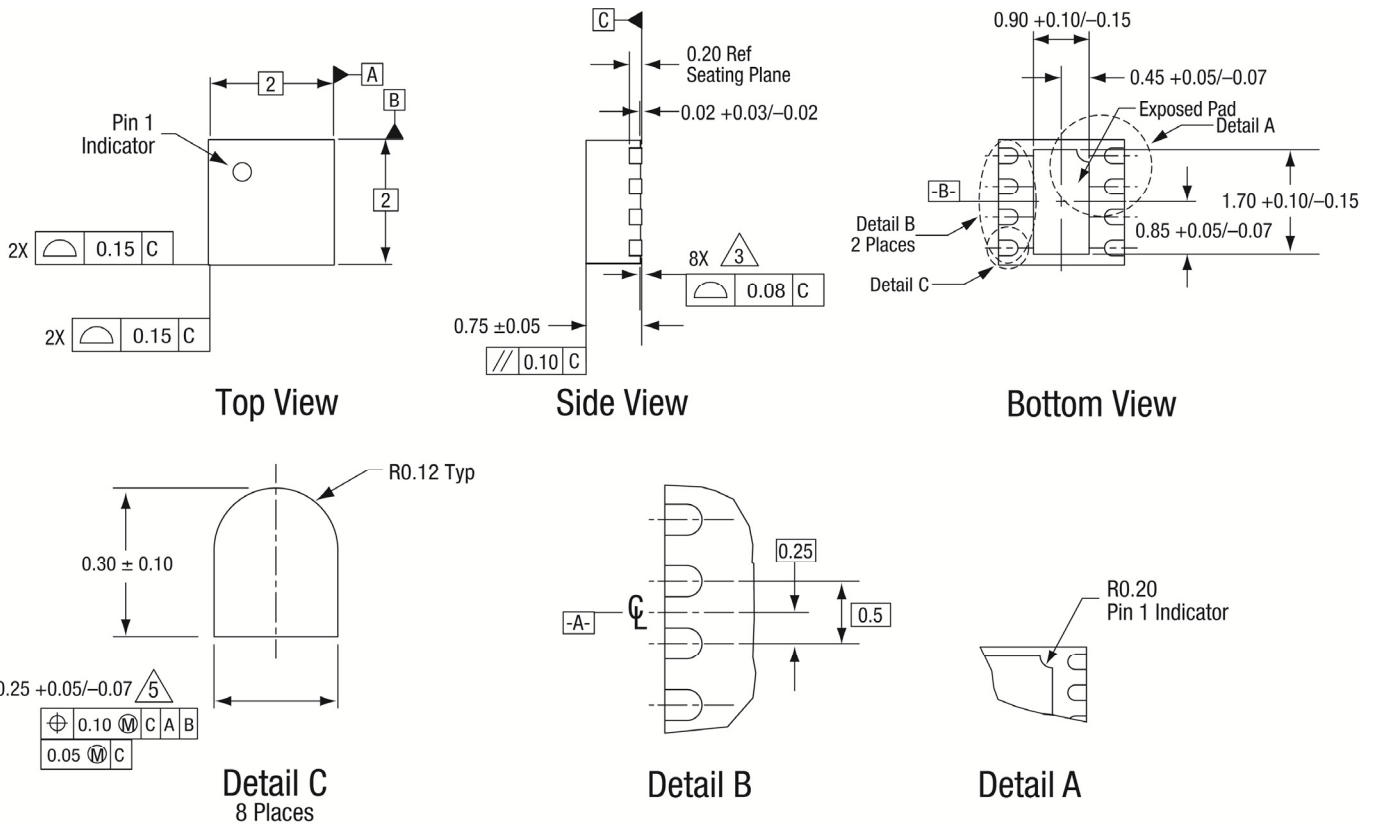

Figure 62. SKY67181-396LF PCB Layout Footprint



Notes:

1. All measurements are in millimeters.
2. Dimensions and tolerances according to ASME Y14.5M-1994.
3. Coplanarity applies to the exposed heat sink ground pad as well as the terminals.
4. Plating requirement per source control drawing (SCD) 2504.
5. Dimension applies to metallized terminal and is measured between 0.15 mm and 0.30 mm from terminal tip.

205690-008

Figure 63. SKY67181-396LF Package Dimensions

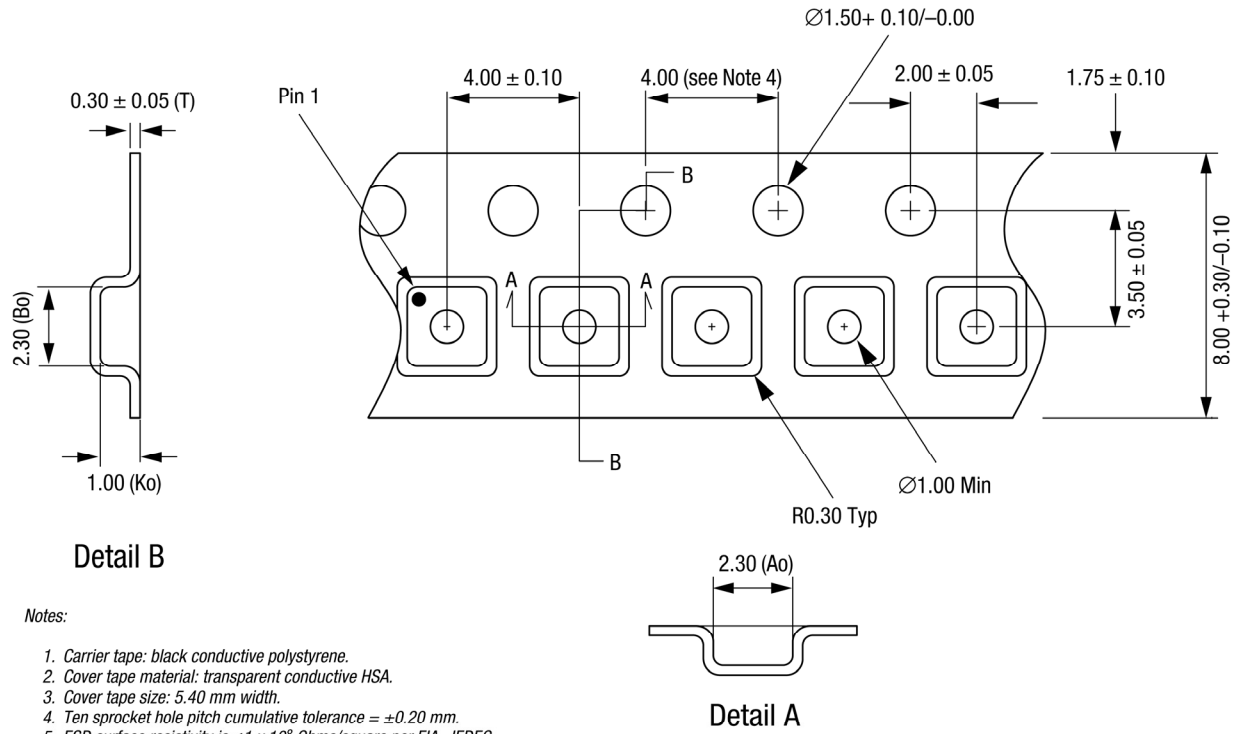

- Detail B**
- Notes:
1. Carrier tape: black conductive polystyrene.
  2. Cover tape material: transparent conductive HSA.
  3. Cover tape size: 5.40 mm width.
  4. Ten sprocket hole pitch cumulative tolerance =  $\pm 0.20$  mm.
  5. ESD surface resistivity is  $\leq 1 \times 10^8$  Ohms/square per EIA, JEDEC tape and reel specification.
  6. Ao and Bo measurement point to be 0.30 mm from bottom pocket.
  7. All measurements are in millimeters.

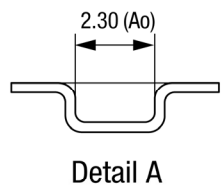

205690-009

**Figure 64. SKY67181-396LF Tape and Reel Dimensions**

## Ordering Information

Part Number	Product Description	Evaluation Board Part Number
SKY67181-396LF	2300 to 5000 MHz Broadband Low-Noise Amplifier	SKY67181-396EK1 (3.3 to 4.2 GHz Tuning)
		SKY67181-396EK2 (4.4 to 5 GHz Tuning)
		SKY67181-396EK3 (2.3 to 2.7 GHz Tuning)
		SKY67181-396EK4 (5.0 to 5.8 GHz Tuning)

Copyright © 2020-2021 Skyworks Solutions, Inc. All Rights Reserved.

Information in this document is provided in connection with Skyworks Solutions, Inc. ("Skyworks") products or services. These materials, including the information contained herein, are provided by Skyworks as a service to its customers and may be used for informational purposes only by the customer. Skyworks assumes no responsibility for errors or omissions in these materials or the information contained herein. Skyworks may change its documentation, products, services, specifications or product descriptions at any time, without notice. Skyworks makes no commitment to update the materials or information and shall have no responsibility whatsoever for conflicts, incompatibilities, or other difficulties arising from any future changes.

No license, whether express, implied, by estoppel or otherwise, is granted to any intellectual property rights by this document. Skyworks assumes no liability for any materials, products or information provided hereunder, including the sale, distribution, reproduction or use of Skyworks products, information or materials, except as may be provided in Skyworks' Terms and Conditions of Sale.

THE MATERIALS, PRODUCTS AND INFORMATION ARE PROVIDED "AS IS" WITHOUT WARRANTY OF ANY KIND, WHETHER EXPRESS, IMPLIED, STATUTORY, OR OTHERWISE, INCLUDING FITNESS FOR A PARTICULAR PURPOSE OR USE, MERCHANTABILITY, PERFORMANCE, QUALITY OR NON-INFRINGEMENT OF ANY INTELLECTUAL PROPERTY RIGHT; ALL SUCH WARRANTIES ARE HEREBY EXPRESSLY DISCLAIMED. SKYWORKS DOES NOT WARRANT THE ACCURACY OR COMPLETENESS OF THE INFORMATION, TEXT, GRAPHICS OR OTHER ITEMS CONTAINED WITHIN THESE MATERIALS. SKYWORKS SHALL NOT BE LIABLE FOR ANY DAMAGES, INCLUDING BUT NOT LIMITED TO ANY SPECIAL, INDIRECT, INCIDENTAL, STATUTORY, OR CONSEQUENTIAL DAMAGES, INCLUDING WITHOUT LIMITATION, LOST REVENUES OR LOST PROFITS THAT MAY RESULT FROM THE USE OF THE MATERIALS OR INFORMATION, WHETHER OR NOT THE RECIPIENT OF MATERIALS HAS BEEN ADVISED OF THE POSSIBILITY OF SUCH DAMAGE.

Skyworks products are not intended for use in medical, lifesaving or life-sustaining applications, or other equipment in which the failure of the Skyworks products could lead to personal injury, death, physical or environmental damage. Skyworks customers using or selling Skyworks products for use in such applications do so at their own risk and agree to fully indemnify Skyworks for any damages resulting from such improper use or sale.

Customers are responsible for their products and applications using Skyworks products, which may deviate from published specifications as a result of design defects, errors, or operation of products outside of published parameters or design specifications. Customers should include design and operating safeguards to minimize these and other risks. Skyworks assumes no liability for applications assistance, customer product design, or damage to any equipment resulting from the use of Skyworks products outside of Skyworks' published specifications or parameters.

Skyworks, the Skyworks symbol, Sky5®, SkyOne®, SkyBlue™, Skyworks Green™, Clockbuilder®, DSPLL®, ISOModem®, ProSLIC®, and SiPHY® are trademarks or registered trademarks of Skyworks Solutions, Inc. or its subsidiaries in the United States and other countries. Third-party brands and names are for identification purposes only and are the property of their respective owners. Additional information, including relevant terms and conditions, posted at [www.skyworksinc.com](http://www.skyworksinc.com), are incorporated by reference.