

PRODUCT SUMMARY

SKY58281-11 Sky5® Front End Module for LTE and NR

Applications

- Multi-band 4G/5G handsets
- Band B42, B43, B48, n77, n78, and n79
- Supports n77, n79 Downlink CA

Features

- UHB LPAMiF for B42, B43, B48, n77, n78, and n79
- Fully Baseband Agnostic Design
- Full Power APT support without DPD
- n78, n79 PC2 power support
- Integrated n77, n78 and n79 primary and MIMO Rx path
- MIPI® v3.0 compliant 52 MHz RFFE bus
- High performance APT/ET PA cores
- Supports 2x2 UL-MIMO using two TX placements
- Supports Fast SRS Hopping timing requirements
- Integrated ANT swap switch
- Integrated SRS_IN/OUT port supports full SRS connectivity
- Switchable LAA input
- 50 ohm input/output impedance with internal DC-blocking
- Continuous bias control via RFFE interface
- Low leakage current in power-down mode
- High performance integrated LNA with MIPI® control features:
 - Up to seven gain modes
 - Independent gain and bias control
- Integrated wide bandwidth filters
- Small, low profile package:
 - 4.5 mm x 5.5 mm x 0.7 mm (Max.)
 - 42-pad configuration
 - LGA with conformal shielding

Description

The SKY58281-11 Front End Module (FEM) for LTE and NR is a new addition to our Sky5 portfolio of 5G Technology products. Key advances compared to previous generation dual band UHB modules are integrated MIMO Rx path and increased output power. Its higher Pout enables PC2 support for n78 and n79. This versatile and fully matched FEM supports multi-band 4G/5G and LTE/NR applications.

Packaged in a single 4.5 mm x 5.5 mm x 0.7 mm (Max.) form factor, the 42-pad surface mount (SMT) module consists of PA blocks, input and output matching, a MIPI standard digital control block, single-ended filters, antenna and band select switches and low Noise amplifier (LNA).

Utilizing an enhanced architecture, the SKY58281-11 covers multiple bands and meets the spectral linearity and EVM requirements of CP-OFDM and DFTS-OFDM modulations up to 256 QAM. Output power is controlled by varying input power and adjusting VCC maximizes efficiency. Extremely low leakage current maximizes handset stand-by time.

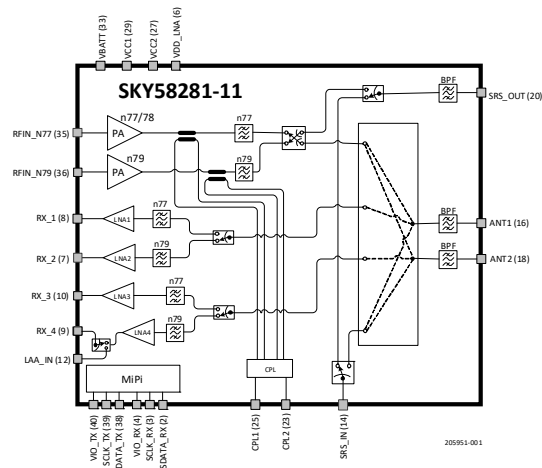



Figure 1. SKY58281-11 Functional Block Diagram

 Skyworks Green™ products are compliant with all applicable legislation and are halogen-free. For additional information, refer to *Skyworks Definition of Green™*, document number SQ04-0074.

Ordering Information

Part Number	Part Description	Evaluation Board Part Number
SKY58281-11	Front End Module for LTE and NR	SKY58281-11EK1

References

Skyworks Application Note: *PCB Design and SMT Assembly/Rework Guidelines for MCM-L Packages; Document Number 101752*

Standard SMT Reflow Profiles: *JEDEC Standard J-STD-020*

Electrostatic Discharge Sensitivity (ESD) Testing: *JEDEC Standard, JESD22-A114 Human Body Model (HBM)*

Electrostatic Discharge Sensitivity (ESD) Testing: *JEDEC Standard, JESD22-A115 Machine Model (MM)*

Electrostatic Discharge Sensitivity (ESD) Testing: *JEDEC Standard, JESD22-C101 Charged Device Model (CDM)*

Testing & Measurement Techniques: *Electrostatic Discharge Immunity Test, IEC 61000-4-2*

Copyright © 2024, Skyworks Solutions, Inc. All Rights Reserved.

Information in this document is provided in connection with Skyworks Solutions, Inc. ("Skyworks") products or services. These materials, including the information contained herein, are provided by Skyworks as a service to its customers and may be used for informational purposes only by the customer. Skyworks assumes no responsibility for errors or omissions in these materials or the information contained herein. Skyworks may change its documentation, products, services, specifications or product descriptions at any time, without notice. Skyworks makes no commitment to update the materials or information and shall have no responsibility whatsoever for conflicts, incompatibilities, or other difficulties arising from any future changes.

No license, whether express, implied, by estoppel or otherwise, is granted to any intellectual property rights by this document. Skyworks assumes no liability for any materials, products or information provided hereunder, including the sale, distribution, reproduction or use of Skyworks products, information or materials, except as may be provided in Skyworks' Terms and Conditions of Sale.

THE MATERIALS, PRODUCTS AND INFORMATION ARE PROVIDED "AS IS" WITHOUT WARRANTY OF ANY KIND, WHETHER EXPRESS, IMPLIED, STATUTORY, OR OTHERWISE, INCLUDING FITNESS FOR A PARTICULAR PURPOSE OR USE, MERCHANTABILITY, PERFORMANCE, QUALITY OR NON-INFRINGEMENT OF ANY INTELLECTUAL PROPERTY RIGHT; ALL SUCH WARRANTIES ARE HEREBY EXPRESSLY DISCLAIMED. SKYWORKS DOES NOT WARRANT THE ACCURACY OR COMPLETENESS OF THE INFORMATION, TEXT, GRAPHICS OR OTHER ITEMS CONTAINED WITHIN THESE MATERIALS. SKYWORKS SHALL NOT BE LIABLE FOR ANY DAMAGES, INCLUDING BUT NOT LIMITED TO ANY SPECIAL, INDIRECT, INCIDENTAL, STATUTORY, OR CONSEQUENTIAL DAMAGES, INCLUDING WITHOUT LIMITATION, LOST REVENUES OR LOST PROFITS THAT MAY RESULT FROM THE USE OF THE MATERIALS OR INFORMATION, WHETHER OR NOT THE RECIPIENT OF MATERIALS HAS BEEN ADVISED OF THE POSSIBILITY OF SUCH DAMAGE.

Skyworks products are not intended for use in medical, lifesaving or life-sustaining applications, or other equipment in which the failure of the Skyworks products could lead to personal injury, death, physical or environmental damage. Skyworks customers using or selling Skyworks products for use in such applications do so at their own risk and agree to fully indemnify Skyworks for any damages resulting from such improper use or sale.

Customers are responsible for their products and applications using Skyworks products, which may deviate from published specifications as a result of design defects, errors, or operation of products outside of published parameters or design specifications. Customers should include design and operating safeguards to minimize these and other risks. Skyworks assumes no liability for applications assistance, customer product design, or damage to any equipment resulting from the use of Skyworks products outside of Skyworks' published specifications or parameters.

Skyworks, the Skyworks symbol, Sky5®, SkyOne®, SkyBlue™, Skyworks Green™, ClockBuilder®, DSPLL®, ISOModem®, ProSLIC®, SiPHY®, and RFelC® are trademarks or registered trademarks of Skyworks Solutions, Inc. or its subsidiaries in the United States and other countries. Third-party brands and names are for identification purposes only and are the property of their respective owners. Additional information, including relevant terms and conditions, posted at www.skyworksinc.com, are incorporated by reference.