



SKY67177-11: 2.3 to 5 GHz High Gain, Low Noise Amplifier with Bypass

Applications

- 4G LTE and 5G NR base stations
- Massive MIMO active antenna array
- Receive LNA for micro-cell, macro-cell and massive MIMO base stations
- Land mobile radios and military communications

Features

- Gain 34 dB @ 3.8 GHz
- Low noise figure 0.7 dB @ 3.8 GHz
- High IP3 performance:
 - IIP3 = -2 dBm @ 3.8 GHz, high gain mode
 - IIP3 = +13 dBm @ 3.8 GHz, bypass mode
- Low current
- Temperature and process-stable active bias up to +115 °C
- QFN (16-pin 3 x 3 mm) package (MSL1 @ 260 °C per JEDEC J-STD-020)



Skyworks Green™ products are compliant with all applicable legislation and are halogen-free. For additional information, refer to *Skyworks Definition of Green™*, document number SQ04-0074.

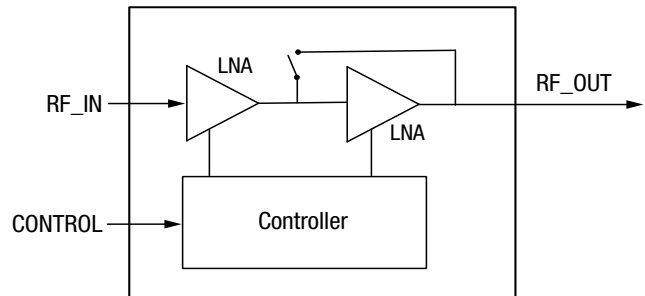

205909-001

Figure 1. Block Diagram

Description

The SKY67177-11 is a high gain low-noise amplifier with second stage bypass and exceptional linearity.

The compact 3 x 3 mm, 16-pin QFN package LNA is designed for 4G LTE and 5G NR base stations operating from 2.3 to 5 GHz.

The internal active bias circuitry provides stable performance over temperature and process variation.

A functional block diagram is shown in Figure 1. The pin configuration and package are shown in Figure 2. Signal pin assignments and functional pin descriptions are provided in Table 1.

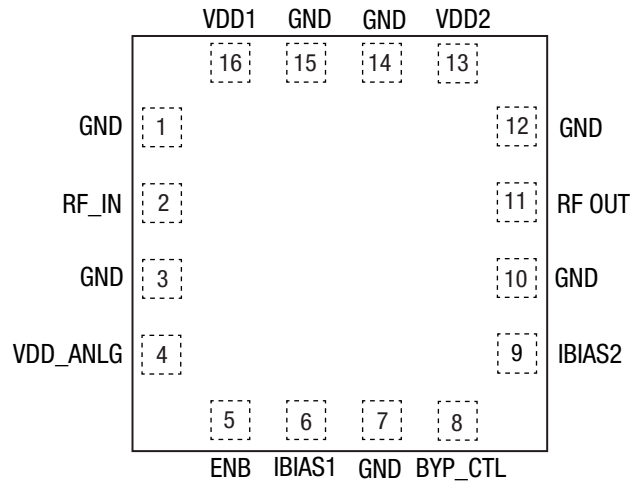

205909-002

Figure 2. Pinout (Top View)

Table 1. Signal Descriptions

Pin	Name	Description	Pin	Name	Description
1	GND	Ground	9	IBIAS2	Stage 2 amplifier current set
2	RF_IN	RF input	10	GND	Ground
3	GND	RF/DC ground	11	RF_OUT	RF output port
4	VDD_ANLG	+5 V analog control voltage supply	12	GND	Ground
5	ENB	Amplifier enabled or disabled mode of operation	13	VDD2	+5 V Stage 2 amplifier bias voltage supply
6	IBIAS1	Stage 1 amplifier current set	14	GND	Ground
7	GND	Ground	15	GND	Ground
8	BYP_CTL	Controls second stage amplifier bypass mode of operation	16	VDD1	+5 V stage 1 amplifier bias voltage supply

Electrical and Mechanical Specifications

The absolute maximum ratings of the SKY67177-11 are provided in Table 2. Electrical specifications are provided in Table 3.

Table 2. Absolute Maximum Ratings¹

Parameter	Symbol	Minimum	Maximum	Units
Supply voltage	$V_{DD1}, V_{DD2}, V_{DD_ANLG}$	0	5.5	V
Quiescent supply current	I_{DQ}		170	mA
RF CW input power	P_{IN}		19	dBm
RF peak input power, LTE-TDD, @ T = 105 °C Pavg = +19 dBm, PAR = 9 dB	P_{IN}		28	dBm
Storage temperature	T_{STG}	-40	+150	°C
Operating temperature	T_C	-40	+115	°C
Junction temperature	T_J		+150	°C
Thermal resistance	θ_{JC}		50	°C/W
Electrostatic discharge: Human Body Model Charge Device Model	HBM CDM	1.25 1		KV KV

1. Exposure to maximum rating conditions for extended periods may reduce device reliability. Exceeding any of the limits listed here may result in permanent damage to the device.

ESD Handling: Industry-standard ESD handling precautions must be adhered to at all times to avoid damage to this device.

Table 3. Electrical Specifications for 3.3 to 4.2 GHz Optimized Tuning, BOM2¹
 (V_{DD1} = V_{DD2} = V_{DD_ANLG} = 5.0 V, T_c = +25 °C², Characteristic Impedance [Z₀] = 50 Ω, Unless Otherwise Noted)

Parameter	Symbol	Test Condition	Min	Typ	Max	Units
RF Specifications						
Gain (high gain mode)	S21 HG	Test freq = 3300 MHz Test freq = 3800 MHz Test freq = 4200 MHz	32 32 32	34 34 34	36 36 36	dB
Gain (bypass mode)	S21 BP	Test freq = 3300 MHz Test freq = 3800 MHz Test freq = 4200 MHz		15 15 15		dB
Gain Ripple	Grp	Freq: 3300 to 4200 MHz (200 MHz Bandwidth) Freq: 3300 to 4200 MHz (600 MHz Bandwidth)		0.25 0.45	0.45 0.7	dB
Reverse Isolation	S12	RF_out to RF_in Test freq = 3300 MHz Test freq = 3800 MHz Test freq = 4200 MHz	47 47 47	50 50 50		dB
Input return loss (high gain mode)	S11 HG	@ 3300 MHz @ 3800 MHz @ 4200 MHz	15 15 15	17 17 17		dB
Input return loss (bypass mode) ³	S11 BP	Test freq = 3300 MHz Test freq = 3800 MHz Test freq = 4200 MHz		17 17 17		dB
Output return loss (high gain mode)	S22 HG	Test freq = 3300 MHz Test freq = 3800 MHz Test freq = 4200 MHz	10 10 10	13 13 13		dB
Output return loss (bypass mode)	S22 BP	Test freq = 3300 MHz Test freq = 3800 MHz Test freq = 4200 MHz		13 13 13		dB
Noise figure (high gain mode)	NFHG	Test freq = 3300 MHz Test freq = 3800 MHz Test freq = 4200 MHz		0.6 0.6 0.6	1.0 1.0 1.0	dB
Noise figure (bypass mode)	NFBP	Test freq = 3300 MHz Test freq = 3800 MHz Test freq = 4200 MHz		0.8 0.8 0.8		dB
Third order input intercept point (high gain mode)	IIP3HG	PIN = -33 dBm/Tone, Δ Tone = 1 MHz @ 3300 MHz @ 3800 MHz @ 4200 MHz	-3 -4 -6	-1 -2 -4		dBm
Third order input intercept point (bypass mode)	IIP3BP	PIN = -20 dBm/Tone, Δ Tone = 1 MHz Test freq = 3300 MHz Test freq = 3800 MHz Test freq = 4200 MHz		13 14 15		dBm
Input 1dB compression point (high gain mode)	IP1dBHG	Test freq = 3300 MHz Test freq = 3800 MHz Test freq = 4200 MHz	-17 -17 -17	-14 -14 -14		dBm
Input 1dB compression point (bypass mode)	IP1dBBP	Test freq = 3300 MHz Test freq = 3800 MHz Test freq = 4200 MHz		3 2 2		dBm
Switching time	T _s	Settling time 50% DC control signal to 0.2 dB of final RF value		0.8	1	uS

1. Performance is guaranteed only under the conditions listed in this table and is not guaranteed over the full operating or storage temperature ranges. Operation at elevated temperatures may reduce reliability of the device.
2. Production tested at 25 °C. Performance over temperature is verified by characterization from -40 °C to 105 °C and over voltage from 4.75 V to 5.25 V.
3. 200 MHz and 600 MHz specifications would require different external Tune BOM.

Table 4. Electrical Specifications for 2.3 to 2.7 GHz Optimized Tuning, BOM1
 (VDD1 = VDD2 = VDD_ANLG = 5.0 V, Tc = +25 °C, Characteristic Impedance [Zo] = 50 Ω, Unless Otherwise Noted)

Parameter	Symbol	Test Condition	Min	Typ	Max	Units
<i>RF Specifications</i>						
Gain (high gain mode)	S21 HG	Test freq = 2300 MHz Test freq = 2500 MHz Test freq = 2700 MHz	32 32 32	34.5 34.5 34.5	37 37 37	dB
Gain (bypass mode)	S21 BP	Test freq = 2300 MHz Test freq = 2500 MHz Test freq = 2700 MHz		15.5 15 15		dB
Gain Ripple	Grp	Freq: 2300 to 2700 MHz (200 MHz Bandwidth)		0.4	0.8	dB
Reverse Isolation	S12	RF_out to RF_in Test freq = 2300 MHz Test freq = 2500 MHz Test freq = 2700 MHz	47 47 47	55 55 55		dB
Input return loss (high gain mode)	S11 HG	@ 2300 MHz @ 2500 MHz @ 2700 MHz	14 14 14	18 18 18		dB
Input return loss (bypass mode)	S11 BP	Test freq = 2300 MHz Test freq = 2500 MHz Test freq = 2700 MHz		20 18 16		dB
Output return loss (high gain mode)	S22 HG	Test freq = 2300 MHz Test freq = 2500 MHz Test freq = 2700 MHz	9 9 9	12 12 12		dB
Output return loss (bypass mode)	S22 BP	Test freq = 2300 MHz Test freq = 2500 MHz Test freq = 2700 MHz		18 13 11		dB
Noise figure (high gain mode)	NFHG	Test freq = 2300 MHz Test freq = 2500 MHz Test freq = 2700 MHz		0.6 0.6 0.6	1.0 1.0 1.0	dB
Noise figure (bypass mode)	NFBP	Test freq = 2300 MHz Test freq = 2500 MHz Test freq = 2700 MHz		0.6 0.6 0.6		dB
Third order input intercept point (high gain mode)	IIP3HG	PIN = -33 dBm/Tone, Δ Tone = 1 MHz @ 2300 MHz @ 2500 MHz @ 2700 MHz	-7 -7 -7	-4 -4 -4		dBm
Third order input intercept point (bypass mode)	IIP3BP	PIN = -20 dBm/Tone, Δ Tone = 1 MHz Test freq = 2300 MHz Test freq = 2500 MHz Test freq = 2700 MHz		10 11.5 12		dBm
Input 1dB compression point (high gain mode)	IP1dBHG	Test freq = 2300 MHz Test freq = 2500 MHz Test freq = 2700 MHz	-18 -18 -18	-15 -15 -15		dBm
Input 1dB compression point (bypass mode)	IP1dBBP	Test freq = 2300 MHz Test freq = 2500 MHz Test freq = 2700 MHz		1 1.2 1.5		dBm
Switching time	Ts	Settling time 50% DC VPD control signal to 0.2 dB of final RF value		0.8	1	uS

Table 5. Electrical Specifications for 4.8 to 5.0 GHz Optimized Tuning, BOM3
 (V_{DD1} = V_{DD2} = V_{DD_ANLG} = 5.0 V, T_c = +25 °C, Characteristic Impedance [Z₀] = 50 Ω, Unless Otherwise Noted)

Parameter	Symbol	Test Condition	Min	Typ	Max	Units
<i>RF Specifications</i>						
Gain (high gain mode)	S21 HG	Test freq = 4800 MHz Test freq = 4900 MHz Test freq = 5000 MHz	31.5 31.5 31.5	34 34 34	36 36 36	dB
Gain (bypass mode)	S21 BP	Test freq = 4800 MHz Test freq = 4900 MHz Test freq = 5000 MHz		13.5 13.5 13.5		dB
Gain Ripple	Grp	Freq: 4800 to 5000 MHz (200 MHz bandwidth)		0.8	1.0	dB
Reverse Isolation	S12	RF_out to RF_in Test freq = 4800 MHz Test freq = 4900 MHz Test freq = 5000 MHz	42 42 42	47 47 47		dB
Input return loss (high gain mode)	S11 HG	@ 4800 MHz @ 4900 MHz @ 5000 MHz	12.5 12.5 12.5	17 17 17		dB
Input return loss (bypass mode)	S11 BP	Test freq = 4800 MHz Test freq = 4900 MHz Test freq = 5000 MHz		18 16 13		dB
Output return loss (high gain mode)	S22 HG	Test freq = 4800 MHz Test freq = 4900 MHz Test freq = 5000 MHz	9 9 9	12 12 12		dB
Output return loss (bypass mode)	S22 BP	Test freq = 4800 MHz Test freq = 4900 MHz Test freq = 5000 MHz		10 12 14		dB
Noise figure (high gain mode)	NFHG	Test freq = 4800 MHz Test freq = 4900 MHz Test freq = 5000 MHz		1 1 1	1.6 1.6 1.6	dB
Noise figure (bypass mode)	NFBP	Test freq = 4800 MHz Test freq = 4900 MHz Test freq = 5000 MHz		1.1 1.1 1.2		dB
Third order input intercept point (high gain mode)	IIP3HG	PIN = -33 dBm/Tone, Δ Tone = 1 MHz @ 4800 MHz @ 4900 MHz @ 5000 MHz	-8 -8 -8	-5 -5 -5		dBm
Third order input intercept point (bypass mode)	IIP3BP	PIN = -20 dBm/Tone, Δ Tone = 1 MHz Test freq = 4800 MHz Test freq = 4900 MHz Test freq = 5000 MHz		12.5 13 13		dBm
Input 1dB compression point (high gain mode)	IP1dBHG	Test freq = 4800 MHz Test freq = 4900 MHz Test freq = 5000 MHz	-18 -18 -18	-14 -14 -14		dBm
Input 1dB compression point (bypass mode)	IP1dBBP	Test freq = 4800 MHz Test freq = 4900 MHz Test freq = 5000 MHz		-3 -2 -1		dBm
Switching time	T _s	Settling time 50% DC VPD control signal to 0.2 dB of final RF value		0.8	1.0	uS

Table 6. DC Electrical Specifications¹

(V_{DD1} = V_{DD2} = V_{DD_ANLG} = 5.0 V, T_c = +25 °C², Characteristic Impedance [Z₀] = 50 Ω, Unless Otherwise Noted)

Parameter	Symbol	Test Condition	Min	Typ	Max	Units
Supply voltage	V _{dd}		4.75	5.0	5.25	V
Quiescent current	I _{CQ}			120	145	mA
Operating temperature	T _C		-40		105	°C
Logic high level	V _{IH}		1.17		3.3	V
Logic low level	V _{IL}		-0.3		0.63	V

1. Performance is guaranteed only under the conditions listed in this table and is not guaranteed over the full operating or storage temperature ranges. Operation at elevated temperatures may reduce reliability of the device.
2. Production tested at 25 °C. Performance over temperature is verified by characterization from -40 °C to 105 °C and over voltage from 4.75 V to 5.25 V.

Table 7. Truth Table

Enable Truth		Bypass Truth	
ENB	Function	BYP_CTL	Function
Low	LNA power on	Low	High gain mode
High	LNA power down	High	Low gain mode (bypass mode)

Evaluation Board Description

An Evaluation Board is used to test the performance of the SKY67177-11. The evaluation board schematic diagram is shown in Figure 3 and the Bill of Materials (BOM) is provided in Tables 8 to 10.

Operational Application

To bias up the SKY67177-11 perform the following power supply and control signal turn-on sequence:

1. Ground all GND connectors.
2. Set ENB and BYPASS_CTRL to LOW.
3. Apply 5.0 V to VDD1, and VDD2, and VDD_ANLG.
4. Apply RF input signal.

To power down the SKY67177-11 perform the following power supply and control signal turn-off sequence:

1. Turn Off RF Input Signal.
2. Set ENB and BYPASS_CTRL to LOW.
3. Apply 0 V to VDD1, VDD2, and VDD_ANLG.

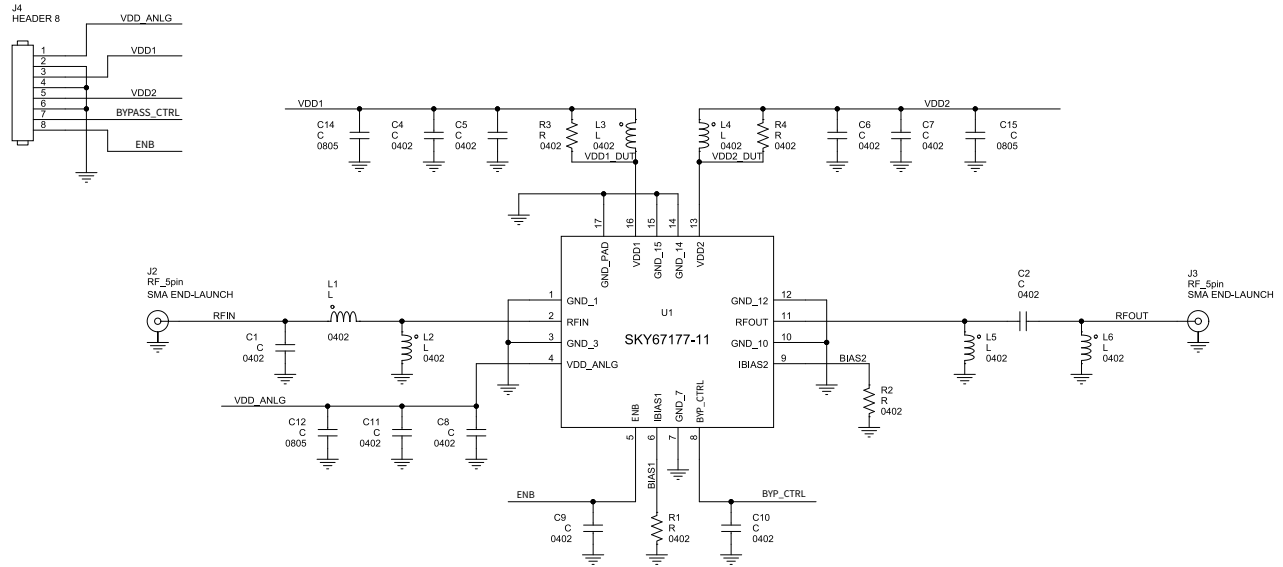

205909-003

Figure 3. Evaluation Board Schematic

Table 8. Evaluation Board Bill of Materials for 2.3 to 2.7 GHz, BOM1

Reference	Value	Manufacturer	Part Number	Size	Description
C1	0.39 pF	Murata	GJM1555C1HR39WB01D	0402	0.39 pF ±0.05 pF 50 V ceramic capacitor COG, NPO (1005 metric)
C2	1.1 pF	Murata	GJM1555C1H1R1WB01D	0402	1.1 pF ±0.05 pF 50 V ceramic capacitor COG, NPO (1005 metric)
C4, C7	47 pF	Murata	GRM1555C1E470JA01D	0402	Multilayer ceramic capacitor MLCC - SMD/SMT 47 pF 25 V DC 5% COG
C5, C6	1 uF	Murata	GRM155C81E105ME11D	0402	Multilayer ceramic capacitor MLCC - SMD/SMT 1 uF 25 V DC 20% X6S
C8	0.1 uF	Murata	GRM155C81E104MA12D	0402	Multilayer ceramic capacitor MLCC - SMD/SMT 0.1 uF 25 V DC 20% X6S
C9	DNI			0402	
C10	DNI			0402	
C11	4.7 uF	Murata	GRM155D81C475ME15D	0402	Multilayer ceramic capacitor MLCC - SMD/SMT 4.7 uF 16 V DC 20% X5S
C12, C14, C15	10 uF	Murata	GRM21BC71E106ME11L	0805	Multilayer ceramic capacitor MLCC - SMD/SMT 10 uF 25 V DC 20% X7S
L1	2.9 nH	Murata	LQW15AN2N7B00D	0402	2.9 nH unshielded drum core, wirewound inductor 750 mA 70 mΩ max (1005 metric)
L2	3.6 nH	Murata	LQW15AN3N6B82D	0402	3.6 nH unshielded drum core, wirewound inductor 1.95 A 30 mΩ max (1005 metric)
L3	5.4 nH	Murata	LQW15AN5N4B82D	0402	5.4 nH unshielded drum core, wirewound inductor 1.77 A 40 mΩ max (1005 metric)
L4	1.6 nH	Murata	LQG15HH1N6B02D	0402	1.6 nH unshielded multilayer inductor 1 A 70 mΩ max (1005 metric)
L5	0.4 pF	Murata	GJM1555C1HR40WB01D	0402	0.4 pF ±0.05 pF 50 V ceramic capacitor COG, NPO
L6	4.7 nH	Murata	LQG15HH4N7B02D	0402	4.7 nH unshielded multilayer inductor 700 mA 160 mΩ max (1005 metric)
R1	8.2 kΩ	Panasonic ECG	ERJ-2RKF8201X	0402	Resistor, SMD 8.2 kΩ 1% 1/10 W
R2	7.5 kΩ	Panasonic ECG	ERJ-2RKF7501X	0402	Resistor, SMD 7.5 kΩ 1% 1/10 W
R3	200 Ω	Panasonic ECG	ERJ-2RKF2000X	0402	Resistor, SMD 220 Ω 1% 1/10 W
R4	220 Ω	Panasonic ECG	ERJ-U02F2200X	0402	Resistor, SMD 220 Ω 1% 1/10 W
J2, J3	SMA RF connectors	Multicomp	R19-070-18-0032210MM	0.062-in. board thickness	SMA connector jack, female socket 50 Ω board edge, end launch solder tab
J4	8 pos header right angle	TE Connectivity	5-103329-8	2.54 mm pitch	Conn header R/A 8 pos 2.54 mm
U1	16-pin QFN	Skyworks Solutions	SKY67177-11	3 mm x 3 mm	2.3 to 5 GHz high gain low-noise amplifier with bypass
PCB		Skyworks Solutions	EN53-D725-001_v1		

Table 9. Evaluation Board Bill of Materials for 3.3 to 4.2 GHz, BOM2

Reference	Value	Manufacturer	Part Number	Size	Description
C1	0.7 pF	Murata	GJM1555C1HR70WB01D	0402	Multilayer ceramic capacitor MLCC - SMD/SMT 0.7 pF 50 V DC 0.05 pF COG
C2	0.7 nH	TDK	MHQ1005P0N7BT000	0402	RF inductor - SMD IND 0402 0.7 nH S-HQ SMD RF IND
C4, C7	47 pF	Murata	GRM1555C1E470JA01D	0402	Multilayer ceramic capacitor MLCC SMD/SMT 47 pF 25 V DC 5% COG
C5, C6	1 uF	Murata	GRM155C81E105ME11D	0402	Multilayer ceramic capacitor MLCC SMD/SMT 1 uF 25 V DC 20% 0402 X6S
C8	0.1 uF	Murata	GRM155C81E104MA2D	0402	Multilayer ceramic capacitor MLCC SMD/SMT 0.1 uF 25 V DC 20% X6S
C9	DNI			0402	
C10	DNI			0402	
C11	4.7 uF	Murata	GRM155D81C475ME15D	0402	Multilayer ceramic capacitor MLCC SMD/SMT 4.7 uF 16 V DC 20% X5S
C12, C14, C15	10 uF	Murata	GRM21BC71E106ME11L	0805	Multilayer ceramic capacitor MLCC SMD/SMT 10 uF 25 V DC 20% X7S
L1	0.8 nH	TDK	MHQ1005P0N8BT000	0402	RF inductor - SMD IND 0.8 nH S-HQ SMD RF IND
L2	1.5 nH	Murata	LQW15AN1N5B00D	0402	1.5 nH unshielded drum core, wirewound inductor 1 A 30 mΩ max
L3, L4	2.4 nH	Murata	LQG15HS2N4B02D	0402	Fixed inductor, 2.4 nH 850 mA, 110 mΩ SMD
L5	0.2 pF	Murata	GJM1555C1HR20WB01D	0402	0.2 pF ±0.05 pF 50 V ceramic capacitor COG, NPO
L6	430 Ω	Murata	ERJ-2RKF4300X	0402	Resistor, SMD 430 Ω 1% 1/10 W
R1	8.2 kΩ	Panasonic ECG	ERJ-2RKF8201X	0402	Resistor, SMD 8.2 kΩ 1% 1/10 W
R2	7.5 kΩ	Panasonic ECG	ERJ-2RKF7501X	0402	Resistor, SMD 7.5 kΩ 1% 1/10 W
R3, R4	620 Ω	Panasonic ECG	ERJ-2RKF6200X	0402	Resistor, SMD 620 Ω 1% 1/10 W
J2, J3	SMA RF connectors	Cinch Connectivity Solutions	R19-070-18-0032210MM	0.062" board thickness	SMA connector jack, female socket 50 Ω board edge, end launch solder tab
J4	8 pos header right angle	TE Connectivity	5-103329-8	2.54 mm pitch	Conn header R/A 8 pos 2.54 mm
U1	16-pin QFN	Skyworks Solutions	SKY67177-11	3mm x 3mm	2.3 to 5 GHz high gain low-noise amplifier with bypass
PCB		Skyworks Solutions	EN53-D725-001_V1		

Table 10. Evaluation Board Bill of Materials for 4.8 to 5.0 GHz, BOM3

Reference	Value	Manufacturer	Manufacturer Part Number	Size	Description
C1	0.8 pF	Murata	GJM1555C1HR80WB01D	0402	0.8 pF ±0.05 pF 50 V ceramic capacitor C0G, NP0
C2	0.9 pF	Murata	GJM1555C1HR90WB01D	0402	0.9 pF ±0.05 pF 50 V ceramic capacitor C0G, NP0
C4, C7	47 pF	Murata	GRM1555C1E470JA01D	0402	Multilayer ceramic capacitor MLCC SMD/SMT 47 pF 25 V DC 5% C0G
C5, C6	1 uF	Murata	GRM155C81E105ME11D	0402	Multilayer ceramic capacitor MLCC SMD/SMT 1 uF 25 V DC 20% X6S
C8	0.1 uF	Murata	GRM155C81E104MA2D	0402	Multilayer ceramic capacitor MLCC SMD/SMT 0.1 uF 25 V DC 20% X6S
C9	DNI			0402	
C10	DNI			0402	
C11	4.7 uF	Murata	GRM155D81C475ME15D	0402	Multilayer ceramic capacitor MLCC SMD/SMT 4.7 uF 16 V DC 20% X5S
C12, C14, C15	10 uF	Murata	GRM21BC71E106ME11L	0805	Multilayer ceramic capacitor MLCC SMD/SMT 10 uF 25 V DC 20% X7S
L1	0.7 nH	TDK	MHQ1005P0N7BT000	0402	RF inductor - SMD IND 0402 0.7 nH S-HQ SMD RF inductor
L2	2.7 nH	Murata	LQW15AN2N7B00	0402	2.7 nH unshielded drum core, wirewound inductor 850 mA 50 mΩ max
L3, L4	0.8 nH	Coilcraft	0402DC-N80XJRW	0402	0.8 nH unshielded wirewound inductor 2.8 A 25 mΩ max
L5	0.2 pF	Murata	GJM1555C1HR20WB01D	0402	0.2 pF ±0.05 pF 50 V ceramic capacitor C0G, NP0
L6	3.9 nH	Murata	LQG15HS3N9S02	0402	Fixed inductor 3.9 nH ±0.3nH 750 mA 140 mΩ SMD
R1	8.2 kΩ	Panasonic ECG	ERJ-2RKF8201X	0402	Resistor, SMD 8.2 kΩ 1% 1/10 W
R2	7.5 kΩ	Panasonic ECG	ERJ-2RKF7501X	0402	Resistor, SMD 7.5 kΩ 1% 1/10 W
R3, R4	499 Ω	Panasonic ECG	ERJ-2RKF4990X	0402	Resistor, SMD 499 Ω 1% 1/10 W
J2, J3	SMA RF connectors	Cinch Connectivity Solutions	R19-070-18-0032210MM	0.062-in. board thickness	SMA connector jack, female socket 50 Ω board edge, end launch solder tab
J4	8 pos header right angle	TE Connectivity	5-103329-8	2.54 mm pitch	Conn header R/A 8 pos 2.54 mm
U1	16-pin QFN	Skyworks Solutions	SKY67177-11	3 mm x 3 mm	2.3 to 5 GHz high gain low-noise amplifier with bypass

Package Dimensions

The package dimensions for the SKY67177-11 are shown in Figure 4. The PCB layout footprint is shown in Figure 5, and tape and reel dimensions are provided in Figure 6.

Package and Handling Information

Since the device package is sensitive to moisture absorption, it is baked and vacuum packed before shipping. Instructions on the shipping container label regarding exposure to moisture after the container seal is broken must be followed. Otherwise, problems related to moisture absorption may occur when the part is subjected to high temperature during solder assembly.

The SKY67177-11 is rated to Moisture Sensitivity Level 1 (MSL1) at 260 °C. It can be used for lead or lead-free soldering. For additional information, refer to the Skyworks Application Note, Solder Reflow Information, document number 200164.

Care must be taken when attaching this product, whether it is done manually or in a production solder reflow environment. Production quantities of this product are shipped in a standard tape and reel format.

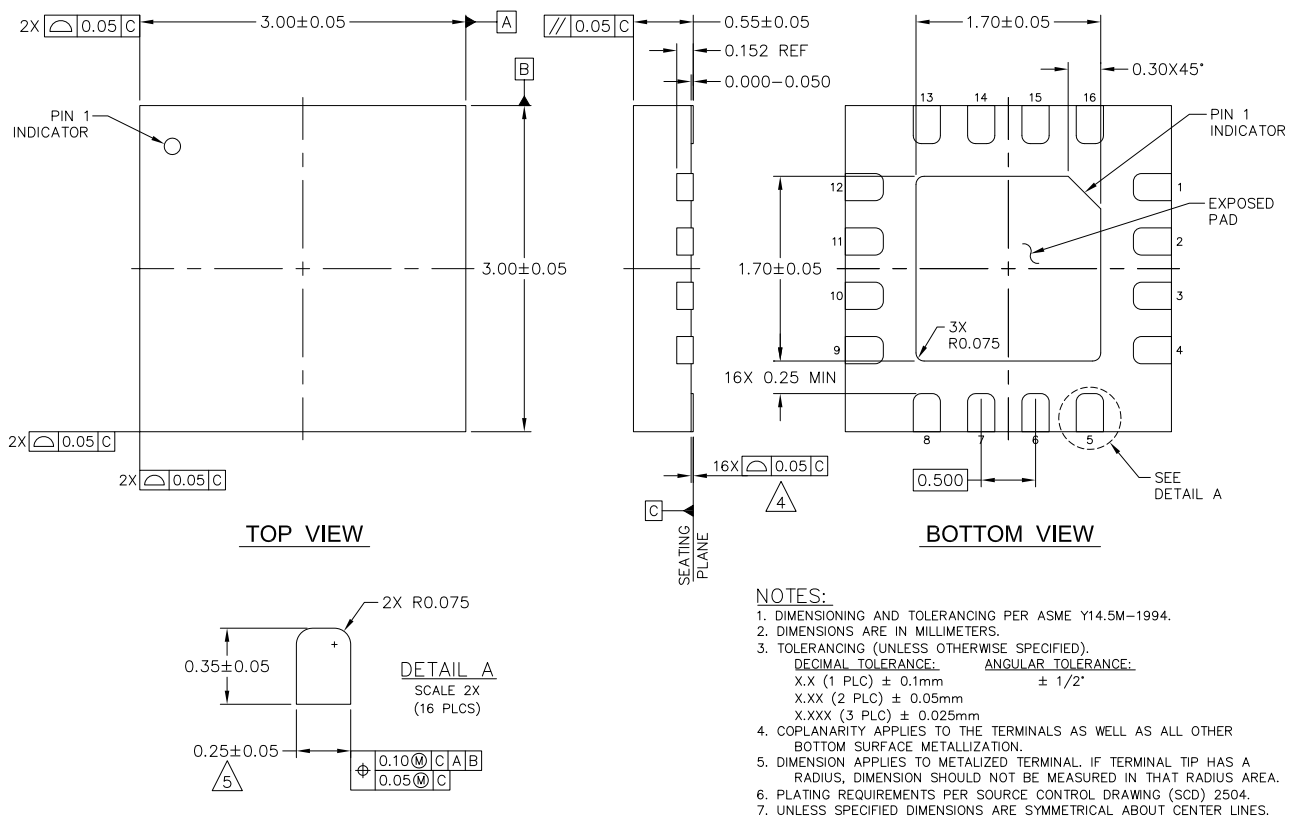

205909-004

Figure 4. Package Dimensions

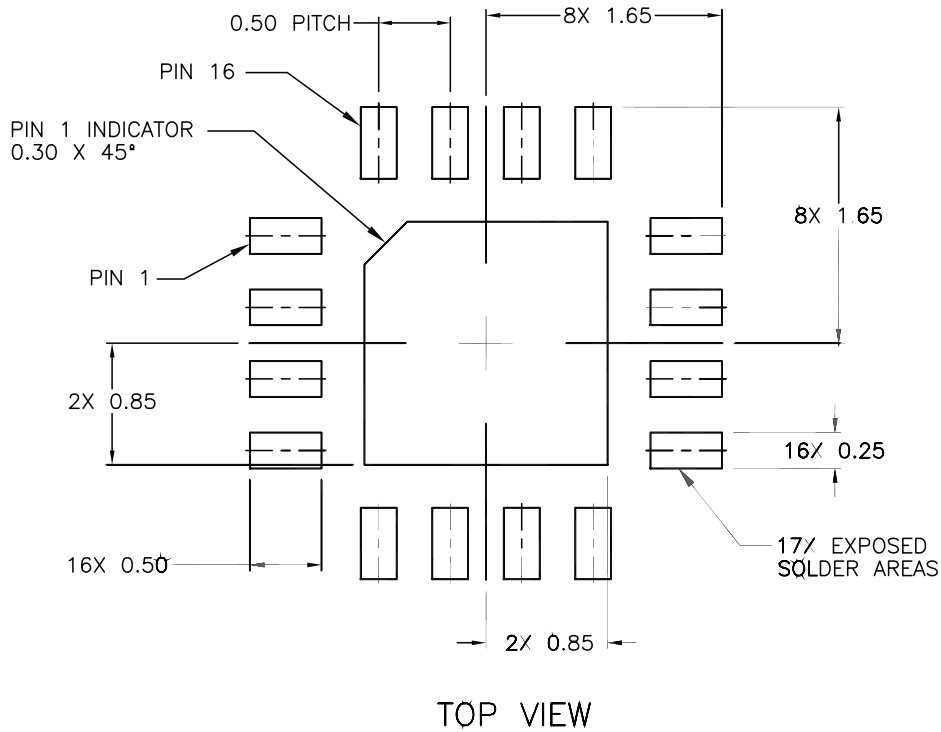

205909-005

Figure 5. PCB Layout Footprint

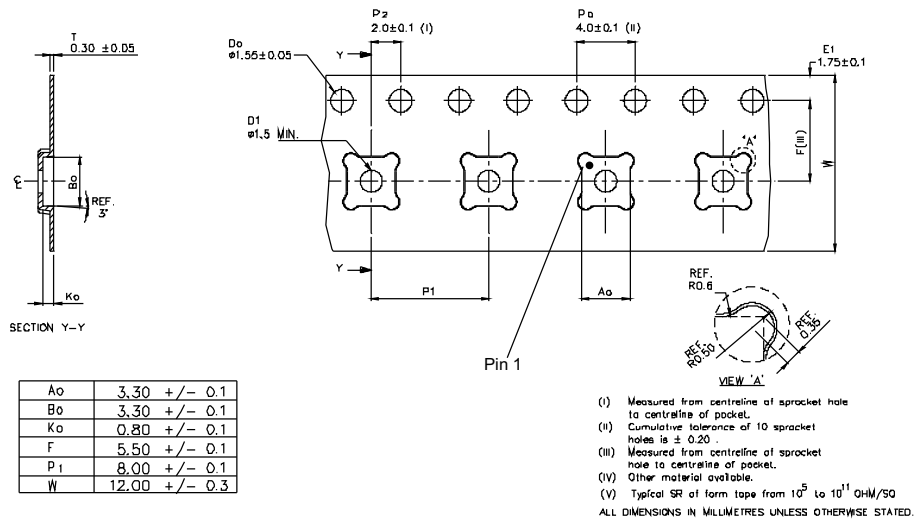

Figure 6. Tape and Reel Dimensions

Ordering Information

Part Number	Part Description	Evaluation Board Part Numbers
SKY67177-11	2.3 to 5 GHz High Gain Low-Noise Amplifier with Bypass	SKY67177-11EK1 (2.3 to 2.7 GHz) SKY67177-11EK2 (3.3 to 4.2 GHz) SKY67177-11EK3 (4.8 to 5.0 GHz)

Copyright © 2021-2024, Skyworks Solutions, Inc. All Rights Reserved.

Information in this document is provided in connection with Skyworks Solutions, Inc. ("Skyworks") products or services. These materials, including the information contained herein, are provided by Skyworks as a service to its customers and may be used for informational purposes only by the customer. Skyworks assumes no responsibility for errors or omissions in these materials or the information contained herein. Skyworks may change its documentation, products, services, specifications or product descriptions at any time, without notice. Skyworks makes no commitment to update the materials or information and shall have no responsibility whatsoever for conflicts, incompatibilities, or other difficulties arising from any future changes.

No license, whether express, implied, by estoppel or otherwise, is granted to any intellectual property rights by this document. Skyworks assumes no liability for any materials, products or information provided hereunder, including the sale, distribution, reproduction or use of Skyworks products, information or materials, except as may be provided in Skyworks' Terms and Conditions of Sale.

THE MATERIALS, PRODUCTS AND INFORMATION ARE PROVIDED "AS IS" WITHOUT WARRANTY OF ANY KIND, WHETHER EXPRESS, IMPLIED, STATUTORY, OR OTHERWISE, INCLUDING FITNESS FOR A PARTICULAR PURPOSE OR USE, MERCHANTABILITY, PERFORMANCE, QUALITY OR NON-INFRINGEMENT OF ANY INTELLECTUAL PROPERTY RIGHT; ALL SUCH WARRANTIES ARE HEREBY EXPRESSLY DISCLAIMED. SKYWORKS DOES NOT WARRANT THE ACCURACY OR COMPLETENESS OF THE INFORMATION, TEXT, GRAPHICS OR OTHER ITEMS CONTAINED WITHIN THESE MATERIALS. SKYWORKS SHALL NOT BE LIABLE FOR ANY DAMAGES, INCLUDING BUT NOT LIMITED TO ANY SPECIAL, INDIRECT, INCIDENTAL, STATUTORY, OR CONSEQUENTIAL DAMAGES, INCLUDING WITHOUT LIMITATION, LOST REVENUES OR LOST PROFITS THAT MAY RESULT FROM THE USE OF THE MATERIALS OR INFORMATION, WHETHER OR NOT THE RECIPIENT OF MATERIALS HAS BEEN ADVISED OF THE POSSIBILITY OF SUCH DAMAGE.

Skyworks products are not intended for use in medical, lifesaving or life-sustaining applications, or other equipment in which the failure of the Skyworks products could lead to personal injury, death, physical or environmental damage. Skyworks customers using or selling Skyworks products for use in such applications do so at their own risk and agree to fully indemnify Skyworks for any damages resulting from such improper use or sale.

Customers are responsible for their products and applications using Skyworks products, which may deviate from published specifications as a result of design defects, errors, or operation of products outside of published parameters or design specifications. Customers should include design and operating safeguards to minimize these and other risks. Skyworks assumes no liability for applications assistance, customer product design, or damage to any equipment resulting from the use of Skyworks products outside of Skyworks' published specifications or parameters.

Skyworks, the Skyworks symbol, Sky5®, SkyOne®, SkyBlue™, Skyworks Green™, ClockBuilder®, DSPLL®, ISOModem®, ProSLIC®, SiPHY®, and RfELC® are trademarks or registered trademarks of Skyworks Solutions, Inc. or its subsidiaries in the United States and other countries. Third-party brands and names are for identification purposes only and are the property of their respective owners. Additional information, including relevant terms and conditions, posted at www.skyworksinc.com, are incorporated by reference.